

XPress



GALVANIZED STEEL



STAINLESS STEEL

Sprinkler systems



Pegler Yorkshire

Pegler Yorkshire

Unrivalled quality, innovation,
customer service and long-term
value for money

As part of the global Aalberts Industries NV Group, Pegler Yorkshire is one of Britain's largest and most respected manufacturers of innovative products for the demanding and diverse plumbing and heating industries.

Pegler Yorkshire – a unique story

It was in the late 19th century when two separate and altruistic companies set out on the long road to satisfying the needs of prospective customers and, of course, to profit in the process. Coincidentally located just 30 miles apart, each was driven by the same vision and ideals of a no-compromise culture. Cutting corners was never an option and only the best could ever be good enough.

These two companies were Pegler and Yorkshire Fittings. In meeting all the challenges of the 20th and 21st centuries both companies have changed a great deal, the business ethos common to both never has. And now these two like minds have come together as Pegler Yorkshire – a single source of proven, flow control solutions for installers, specifiers and engineers in the domestic, public and commercial markets.

Reputable and established brands

Just as Pegler and Yorkshire have endured over such a long period, many of the brand names they have created over time are similarly very well established, in many cases as market leaders in their respective categories. The very extensive Pegler Yorkshire product range now comprises more than 15,000 lines – without rival for the choice and coverage it offers and for the number and scope of applications it satisfies.

A mind for innovation

Brands which endure and are not easily displaced must by definition be the product of innovative thinking and technology that continually stand the test of time. Pegler Yorkshire's no-compromise philosophy will always put new product development high on the agenda, based on not only meeting the needs of today's markets, but also anticipating and meeting customers' future needs.

The true value of knowledge

As well as the benefit of unparalleled experience of the flow control market and its growth over many decades, Pegler Yorkshire has strong associations with major industry bodies such as those responsible for determining product and performance standards.

The result is a comprehensive store of knowledge and reference which is invaluable in the key areas of research, development and dealing efficiently and accurately with customer enquiries – particularly with regard to product application and suitability.

A charter for the best in customer service

With such a diverse product range and customer base, Pegler Yorkshire's no-compromise standards of quality, reliability and value for money naturally go hand in hand with the principle of delivering the best in customer service.

Green awareness and responsibilities

Developing products which reduce the carbon footprint by saving water and energy is only one side of the green issues coin. Pegler Yorkshire is also increasingly committed to recycling key production materials (such as brass), eliminating the need for excessive packaging wherever possible, and looking for new ways in which the company's day-to-day operations can be improved to reduce waste and minimise the impact on the environment.

Likewise, social responsibilities such as supporting employee and local community welfare are aspects of the very fabric and philosophy upon which both Pegler and Yorkshire were founded.

Standards

Pegler Yorkshire is dedicated to designing, developing and manufacturing products of the highest quality. We are members of numerous standards committees and take an active part in their development. Our products, where applicable, comply with the relevant British, European and International standards. Whatever the latest developments, we guarantee that our products will always meet the latest and highest standards.



Trade bodies

Pegler Yorkshire is pleased to be associated with several influential industry organisations:



Association of Plumbing and Heating Contractors



The Bathroom Manufacturers Association



Construction Products Association

Brass

The Brass Page for specifiers, designers, engineers and manufacturers



British Plumbing Employers Council



Builders Merchants Federation



The Copper Development Association



The UK Copper Board



Institute of Plumbing



Heating and Ventilating Contractors Association



Thermostatic Mixing Valve Manufacturers Association



Scottish and Northern Ireland Plumbing Employers Federation



British Automatic Fire Sprinkler Association



Bundesverband Technischer Brandschutz e.V.



European Fire Sprinkler Network

 This data book has been produced in clearly defined sections to help the user to find relevant information quickly and easily. At the foot of each page there is a reminder of the brochure sections with the relevant page numbers.

Section 1

Product range overview

The complete range	4-5
Product overview	6
Standards, approvals and guarantees	7-9

Section 2

Product range details

Galvanised sprinkler system sizes, dimensional details and product codes	10-18
Stainless steel sprinkler system sizes, dimensional details and product codes	19-29
XPress Accessories sizes, dimensional details and product codes	30-31

Section 3

Technical data

Applications	32-34
Materials specification	35-37
Working temperatures	38-39
System design considerations and tube expansion	40

Section 4

Installation instructions

Making a press connection	41
Minimum distance between fittings	42
Available space needed for press tool	43
Bending & general instructions for use	44-45
XPress sprinkler tools	46-49



Your lightweight, easy and fast to install, cost-saving alternative for wet and dry sprinkler installations.

Introduction to XPress sprinkler systems

With the growing importance of the fire safety and security market on one hand and the lack of time on the building site on the other, making the XPress system available for sprinkler installations was an obvious choice.



By obtaining the VdS approval in the beginning of 2008 for both carbon and stainless steel, this was the start to evolve the XPress system into XPress Sprinkler. Many approvals, such as FM, FG, SBSC, LPCB and CNBOP, have followed since and will continue to follow.

XPress sprinkler is available in sizes DN20-DN100 (22-108mm), either in carbon or stainless steel and has been tested and certified for the use in wet and dry fixed waterbased fire fighting systems. The system can operate at working pressures of up to 16 bar, depending on the dimensions and relevant approvals.

Advantages of XPress

In the building installation market the advantages of press systems over traditional solutions such as threading, soldering and welding have long been recognized. The same advantages apply for XPress in sprinkler installations:

- *Performance guaranteed*
- *Reliable*
- *Easy & clean*
- *Safe*
- *Speed*

Apart from these advantages, the aesthetics of a XPress installation (compared to for example black steel) are often a reason for architects and designers to prescribe our system for in-sight/exposed installations.

Performance guaranteed

Manufacturing all fittings in a state-of-the-art factory guarantees consistent quality and supply. High-tech manufacturing, using laser welding technology, ensures that all welded fittings are tested 100%. This leak test is entirely integrated and automated in the laser welding process. All straight connectors with a threaded end and reducers are made out of one piece, eliminating the risk of leakage and short build-in dimensions.



Performance in flow is obvious, with the extremely smooth surface of tubes and fittings, flow rates are much better than those in traditional solutions. The performance of our fittings can also be measured by the various number of national and international approvals. With certificates for drinking water, in-house gas installations, ship building and now also sprinkler there is a wide range available of system and product approvals.

Reliable Leak Before Press (LBP) feature

In XPress sprinkler systems, the quality of the connection is mainly determined by the tool and not the operator, therefore reducing the risk of installation mistakes. All fittings are equipped with a Leak Before Pressed (LBP) function, to reduce this risk even further. The LBP function is achieved either by a special 'O' ring or by the specific design of the fitting. This LBP function ensures that fittings, which have not been pressed, will leak during the initial pressure test. The installer can immediately see which fitting he forgot to press and correct this. Once pressed, the system is guaranteed water and air tight.



Easy and clean

XPress sprinkler is an extremely user friendly solution:

- *No need to thread the tubes*
- *No lubrication needed for installation*
- *Easy tube insertion of the tube in the fitting due to the special design of fittings*
- *Short radius bends which ensure a compact installation*

Above features make sure that less skills for installation are required and that installation can take place in a more pleasant environment.

Safe

The installation of the XPress sprinkler system does not require a heat source (as for example with welding or soldering)



or other potentially heavy and dangerous tools. This feature makes XPress Sprinkler an ideal solution for retrofit or renovation projects, since you can ensure a minimum of disturbances during installation.

Moreover, the light weight of the precision steel tubes ensures improved labour conditions and as such brings a healthier way of working.

Speed

Reduced labour time is probably the most important advantage of the XPress Sprinkler system, not only resulting in reduced costs but also important in times when it is difficult to find sufficiently skilled people to work on the projects.

Based on given advantages, we are sure that the XPress sprinkler system will have your preference for sprinkler installations in particular for distribution and branch systems.

XPress sprinkler, an imPRESSive solution!

XPress sprinkler system – Galvanised steel

The Fittings incorporate a black EPDM (Ethylene Propylene Diene Monomer) 'O' ring and a unique "Leak Before Press" (LBP) design. LBP has been developed as a final check to the system to provide instant identification of joints that have been assembled correctly but mistakenly left unpressed. This feature saves time, money and potentially expensive call backs.

You can recognise the XPress sprinkler range by the laser marking on the fitting which makes it easy for you to identify the fitting used. Information such as material, approvals and dimensions are all permanently marked onto the fitting.

The XPress sprinkler range is a complete system, where the combination of tube, fitting and tools are combined into a certified sprinkler system.

XPress Galvanised Sprinkler system tube can only be used in a sprinkler installation and should not be used in a general plumbing application.

Features

- Available in 22mm to 108mm
- Manufactured from carbon steel
- Leak before press
- Safety – no naked flames, no hotwork permits or costly insurance

Laser marking	Packaging label
XPress	Type C...
Galvanized	Dimension
Approvals	Description: ...C-Pr
Dimension	EAN Nr.
Traceability code	Art Nr Pegler Yorkshire
	Approvals
	Number of pieces

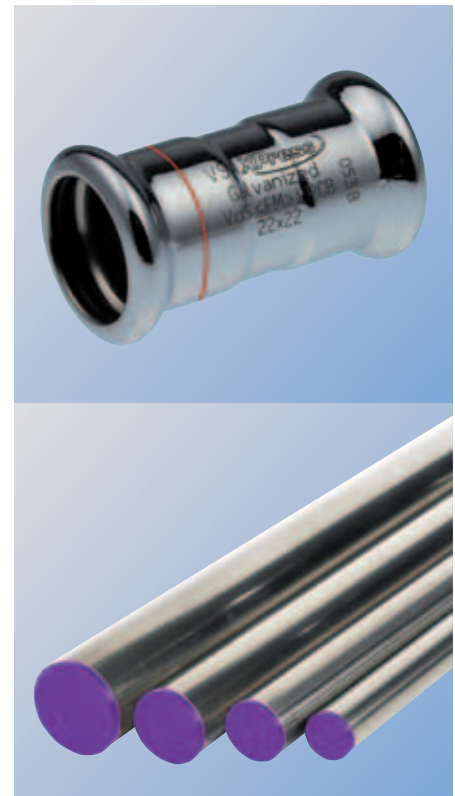

XPress sprinkler system – Stainless steel

The Fittings incorporate a black EPDM (Ethylene Propylene Diene Monomer) 'O' ring and a unique "Leak Before Press" (LBP) design. LBP has been developed as a final check to the system to provide instant identification of joints that have been assembled correctly but mistakenly left unpressed. This feature saves time, money and potentially expensive call backs.

You can recognise the XPress sprinkler range by the laser marking on the fitting which makes it easy for you to identify the fitting used. Information such as material, approvals and dimensions are all permanently marked onto the fitting.

The XPress sprinkler range is a complete system, where the combination of tube, fitting and tools are combined into a certified sprinkler system.

Features

- Available in 22mm to 108mm
- Leak before press
- Clean, heat free jointing
- Lightweight, easy to handle
- 3 tube types

Laser marking	Packaging label
XPress	Type R...
316L	Dimension
Approvals	Description: ...S-PR
Dimension	EAN Nr.
Traceability code	Art Nr Pegler Yorkshire
	Approvals
	Number of pieces



It is Pegler Yorkshire policy to provide a range of products and services which meet, or exceed, the requirements of our customers in respect of quality, cost and delivery.

Standards and approvals

Current and future standards

We at Pegler Yorkshire are dedicated to designing, developing and manufacturing products of the highest quality. It is on this basis that you can trust the XPress range to achieve all relevant British, European and International standards.

Over recent years, tube and fittings for plumbing and heating systems have been subject to a gradual harmonisation of standards. Today, a further harmonisation is taking place that is set to incorporate copper and copper alloy press-fit fittings within pr EN 1254 under Part 7.

It is a sign of our standing in the industry that we at Pegler Yorkshire are helping to draft this and other new European standards, assisted by our fellow members on the various European standards committees.

So, you can rest assured that whatever developments arise, our products will always meet the latest standards.

Sprinkler systems must be designed and installed in accordance with guideline CEA 4001 (VdS) and/or local regulations. Here the following steps must be carried out.

- Planning
- Installation
- Maintenance

PRODUCT APPROVALS		
Approval	XPress Stainless steel	XPress Galvanised
LPCB	✓	✓
FM	✓	✓
VdS	✓	✓

LPCB certificate



The XPress sprinkler system has been tested and certified in accordance with the LPCB guidelines (TS1599 draft 5) for both the galvanized and stainless steel system for use in fixed sprinkler systems for above ground applications. These

guidelines refer to the XPress sprinkler system with a working pressure of as stated in working pressures table in the dimensions DN20 up to DN50 (22-54mm). Except where correct fittings are used to connect the system to other ISO 65 or EN 10255 medium weight piping systems, XPress system components shall not be used in conjunction with other press piping systems. The connection of other non-system components is only admissible via detachable metal connections. It is not allowed to insert additives or anticorrosive agents in the extinguishing water unless previously released by Pegler Yorkshire Fittings. Painting of the installation is

allowed as long as the painting is done after installation and the paint used is water based. For XPress sprinkler installations according to LPCB allowed hazard classes range from LH up to OH3. *76.1-108mm pending LPCB Approval.

XPress sprinkler Stainless LPCB

The XPress sprinkler Stainless system has a LPCB certification for fittings and tubes according the LPCB approval standard TS1599 for the application in wet sprinkler systems with a maximum pressure of 16 bar. XPress sprinkler stainless also allowed to be used in embedded installations. The approval refers to the XPress Sprinkler system in the dimensions DN20 to DN50 (22-54mm). According LPCB the system is certified for using XPress stainless steel tubes with material code 1.4401 (AISI 316), 1.4520 (AISI 439) and 1.4521 (AISI 444). XPress Sprinkler Stainless is WRAS approved in combination with 1.4401 tubes.

XPress sprinkler Galvanized LPCB

The XPress sprinkler Galvanized system has a LPCB certification for fittings and tubes according the LPCB approval standard TS1599 for the application in wet sprinkler systems with a maximum working pressure of 16 bar. The approval refers to the XPress sprinkler system in the dimensions DN20 to DN50 (22-54mm). According LPCB the system is certified for using XPress Galvanized Sendzimir tubes. When installing XPress Galvanized to a potable water network, care should be taken to use a WRAS approved water back flow preventer. Installations made by XPress sprinkler should be inspected regularly on corrosion.

Assembly, installation and maintenance of LPCB approved sprinkler installations

The assembly, installation and maintenance of the XPress sprinkler system may only be performed by trained technical personnel who are qualified to work on sprinkler systems, For example, the guideline LPC Rules for Automatic Sprinkler installation, incorporating BS EN12845 contains the requirements for the assembly and maintenance of a fixed sprinkler system. The company performing the installation must comply at all times with the guidelines. When installing XPress Sprinkler, the installer must always ensure that adequate (meeting the requirements of the building regulations and LPC Sprinkler Rules) fire stopping is undertaken following the routing of the pipes.

<FM> certificate



XPress sprinkler Stainless <FM>

The XPress sprinkler Stainless system has a FM certification for fittings and tubes according FM approval standard 1630 and 1920 for application in wet and dry sprinkler system with a maximum pressure of 175 psi (12.1 bar). The approval refers to the XPress Sprinkler system in the dimensions DN20 to DN100 (22-108mm). According FM the system is certified for using XPress stainless steel tubes with material code 1.4401 (AISI 316), 1.4520 (AISI 439) and 1.4521 (AISI 444). No limitations on hazard classes apply, when using XPress Sprinkler stainless, when installing according to FM standards.

XPress sprinkler Galvanized <FM>

The XPress sprinkler Galvanized system has a FM certification for fittings and tubes according the FM approval standards 1630 and 1920 for the application in wet sprinkler systems with a maximum pressure of 175 psi (12.1 bar). The approval refers to the XPress sprinkler system in the dimensions DN20 to DN50 (22-54mm). According FM the system is certified for using XPress Galvanized Sendzimir tubes. No limitations on hazard classes apply, when using XPress sprinkler Galvanized, when installing according to FM standards.

Assembly and installation of approved sprinkler installations

The assembly and installation of the XPress sprinkler system may only be performed by trained technical personnel who are qualified to work on sprinkler systems. When making a transition from traditional thick wall tubes to the XPress sprinkler system in the dimensions DN20 to DN100 (22-108 mm), it is mandatory to use a transition from press to grooved coupling (product group C 1442 and R 2748).

When installing the transition coupling from press to grooved, always make sure to use the complete insertion depth.

Minimum insertion depth transition coupling		
DN	Outside ø (mm)	Insertion depth (mm)
25	28	46
32	35	52
40	42	60
50	54	70
65	76.1	54
80	88.9	64
100	108	74

VdS certificate



The XPress sprinkler system has been tested and certified in accordance with the VdS guidelines for both the galvanized and stainless steel system for use in fixed sprinkler systems behind the alarm valve. These guidelines refer to the XPress sprinkler system with a working pressure of as stated in table on page 9 in the dimensions DN20 up to DN100 (22-108mm), for all products within in the XPress sprinkler range.

The use is limited to the connection of the system components among each other. The connection of other non-system components is only admissible via detachable metal connections. It is not allowed to insert additives in the extinguishing water. Exceptions are anticorrosive agents according to the manufacturer release and previous agreement with VdS Schadenverhütung. The admissible hanger spacings for copper pipes according to VdS CEA4001 do apply.

XPress sprinkler Stainless VdS

XPress Sprinkler Stainless G4080037

- XPress sprinkler Stainless fitting
- XPress sprinkler Stainless tube
- Press tools

The XPress sprinkler stainless system may be used in fixed wet and dry sprinkler systems in the hazard classes LH up to partially OH4 (theatres, concert halls, movie theatres). The approval applies to the dimensional range with a diameter DN20 to DN100 (22-108mm) with an operating pressure as stated in table 20. The XPress Stainless fittings are made of 1.4404 (AISI 316L) stainless steel, the tubes are made of 1.4401 (AISI 316) stainless steel. The application is limited to installation behind the alarm valve.

XPress sprinkler Galvanized VdS

VdS is a system approval, meaning that the approval is only valid when all components are combined:

XPress Sprinkler Galvanized G4080007

- XPress sprinkler Galvanized fitting
- XPress sprinkler Galvanized tube
- Press tools

The XPress sprinkler Galvanized system may be used in fixed wet sprinkler systems in the hazard classes LH up to partially OH4 (exhibition halls, theatres, concert halls, movie theatres). The approval applies to the dimensional range with a diameter DN20 up to DN100 (22-108mm) with a maximum operating pressure as mentioned in table 20. XPress Sprinkler Galvanized fittings are made of zinc-plated unalloyed steel, combined with a carbon-steel tube produced specifically for the XPress Sprinkler Galvanized system which inner and outer surface is galvanized (Sendzimir tube). The application is limited to installations behind the alarm valve in branch and distribution lines and should be inspected regularly on corrosion.

Assembly and installation of Pegler Yorkshire approved sprinkler installations

The assembly and installation of the XPress Sprinkler system may only be performed by trained technical personnel who are qualified to work on sprinkler systems, For example, the guideline CEA 4001 (VdS) contains the requirements for the assembly of a fixed sprinkler system. The company performing the installation must comply at all times with the guidelines.

ISO



ISO is achieved through the continuous improvement of our Quality Management System in line with the requirements of BS EN ISO 9001: 2008.

Guarantees

10 YEAR GUARANTEE

XPress Carbon Sprinkler is guaranteed against all manufacturing defects for 10 years when installed as a system using the respective XPress Carbon Sprinkler tube and fittings.

25 YEAR GUARANTEE

The XPress Stainless Sprinkler ranges are guaranteed against all manufacturing defects for 25 years when installed as a system using respective XPress Stainless Sprinkler tube and fittings.

XPress Sprinkler system fittings and tube	Guarantee period (years)		
	5	10	25
XPress Stainless steel fittings	-	-	✓
XPress Stainless steel tube	-	-	✓
XPress Galvanised fittings	-	✓	-
XPress Galvanised fittings tube	-	✓	-

To qualify for guarantees, all products must be installed in accordance with our instructions on specified applications.

All of the bodies involved in the acceptance test for the system must be included in the entire process from project planning to the acceptance test itself. Depending on the approvals, different

working pressures apply. Please check the table below for the applicable pressures when installing under VdS, FM or LPCB.

Working pressures XPress Sprinkler							
DN	Nominal width (mm)	VdS		FM		LPCB	
		Wet (C-Press)	Wet and dry (S-Press)	Wet (C-Press)	Wet and dry (S-Press)	Wet (C-Press)	Wet (S-Press)
20	22	16 bar	16 bar	175psi	175psi	16 bar	16 bar
25	28	16 bar	16 bar	175psi	175psi	16 bar	16 bar
32	35	16 bar	16 bar	175psi	175psi	16 bar	16 bar
40	42	16 bar	16 bar	175psi	175psi	16 bar	16 bar
50	54	16 bar	16 bar	175psi	175psi	16 bar	16 bar
65	76.1	12.5 bar	16 bar	-	175psi	-	-
80	88.9	10 bar	12.5 bar	-	175psi	-	-
100	108	10 bar	10 bar	-	175psi	-	-

C-Press: carbon, S-Press: stainless

Galvanized sprinkler system

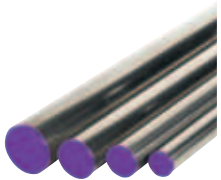

SC645 Galvanized sprinkler tube

Size	Order code
22mm x 1.5mm x 6m	25094
28mm x 1.5mm x 6m	25095
35mm x 1.5mm x 6m	25096
42mm x 1.5mm x 6m	25097
54mm x 1.5mm x 6m	25098
76.1mm x 2mm x 6m	25099
88.9mm x 2mm x 6m	25100
108mm x 2mm x 6m	25101

XPress Galvanised Sprinkler system tube can only be used in a sprinkler installation and should not be used in a general plumbing application.

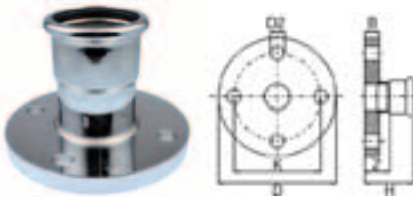

SC1FMF Flanged connector PN 10/16

Size	DN	Z	D	D2	H	K	B	Order code
76.1mm	65	79.0	185.0	18.0	134.0	145.0	18.0	20659
88.9mm	80	78.0	200.0	18.0	141.0	160.0	20.0	20660
108mm	100	88.0	220.0	18.0	166.0	180.0	20.0	20661

Connection: Press x Flange



SC1 Straight coupling

Size	L	Z	Order code
22mm	55.0	13.0	20138
28mm	59.0	13.0	20139
35mm	65.0	13.0	20140
42mm	76.0	16.0	20141
54mm	86.0	16.0	20142
76.1mm	142.0	28.0	20620
88.9mm	160.0	34.0	20621
108mm	199.0	41.0	20622

Connection: Press x Press



SC1R Straight reduced coupling

Size	L	Z	Order code
28 x 22mm	47.5	2.5	20154

Connection: Press x Press

76.1mm - 108mm pending LPCB approval

SC1SLIP Slip coupling

Size	L	es	Order code
22mm	84.0	25.0	20146
28mm	91.0	30.0	20147
35mm	102.0	30.0	20148
42mm	120.0	40.0	20149
54mm	140.0	40.0	20150
76.1mm	230.0	60.0	20623
88.9mm	262.0	70.0	20624
108mm	304.0	80.0	20625

Connection: Press x Press

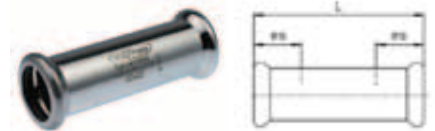

SC1V Transition for grooved coupling

Size	L	D	Z	Order code
28 x 33.7mm	72.5	33.7	26.0	20187
35 x 42.4mm	81.0	42.4	26.0	20188
42 x 48.3mm	86.0	48.3	26.0	20189
54 x 60.3mm	96.5	60.3	26.0	20190
76.1 x 76.1mm	90.0	76.1	36.0	20731
88.9 x 88.9mm	100.0	88.9	36.0	20732
108 x 114.4mm	110.0	114.3	36.0	20733

Connection: Press x Groove



SC2 Straight connector

Size	L	Z	Order code
22mm x 1/2"	36.5	4.5	20245
22mm x 3/4"	43.0	5.7	20240
28mm x 1/2"	38.0	2.0	20244
28mm x 3/4"	40.5	1.0	20246
28mm x 1"	49.0	7.0	20241
35mm x 1 1/4"	50.0	2.3	20247
35mm x 1/2"	42.0	5.3	20365
35mm x 3/4"	43.0	5.2	20366
35mm x 1"	46.0	7.0	20367

Connection: Press x BSP female parallel thread

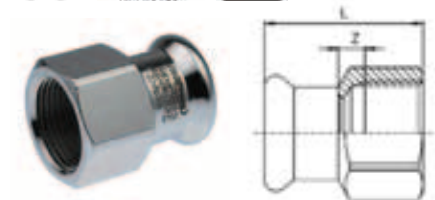

76.1mm - 108mm pending LPCB approval

Galvanized sprinkler system



SC2LC Slip long coupling

Size	A	B	C	ΔL	Order code
22mm x 1/2"	92.0	25.0	15.0	40.0	20323
22mm x 3/4"	97.0	25.0	16.0	40.0	20324
28mm x 1/2"	94.0	30.0	15.0	40.0	20325
28mm x 3/4"	93.0	30.0	16.0	40.0	20326

Connection: Press x BSP parallel female thread

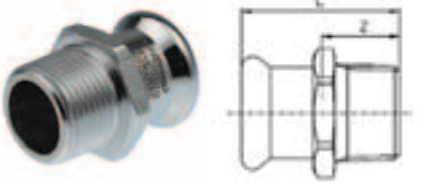

SC3 Straight connector

Size	L	Z	Order code
22mm x 1/2"	43.0	22.0	20242
22mm x 3/4"	44.0	23.0	20231
22mm x 1"	50.0	29.0	20243
28mm x 3/4"	46.0	23.0	20236
28mm x 1"	48.0	25.0	20232
35mm x 1 1/4"	55.0	29.0	20233
42mm x 1 1/2"	59.0	29.0	20234
54mm x 2"	69.0	34.0	20235
76.1mm x 2 1/2"	123.0	68.0	20713
88.9mm x 3"	134.0	71.0	20714

Connection: Press x BSP taper male thread

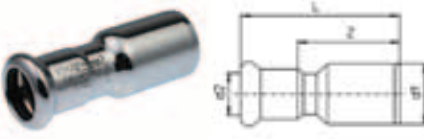

SC6 Reducer

Size	L	Z	d1	d2	Order code
28 x 22mm	63.0	42.0	28.0	22.0	20219
35 x 22mm	68.0	47.0	35.0	22.0	20220
35 x 28mm	69.0	46.0	35.0	28.0	20221
42 x 22mm•	80.0	59.0	42.0	22.0	20248
42 x 28mm	79.0	56.0	42.0	28.0	20212
42 x 35mm	76.0	50.0	42.0	35.0	20222
54 x 22mm•	89.0	68.0	54.0	22.0	20223
54 x 28mm•	87.0	64.0	54.0	28.0	20224
54 x 35mm	89.0	63.0	54.0	35.0	20226
54 x 42mm	91.0	61.0	54.0	42.0	20225
76.1 x 42mm	151.0	121.0	76.1	42.0	20715
76.1 x 54mm	145.0	109.0	76.1	54.0	20639
88.9 x 54mm	157.0	122.0	88.9	54.0	20640
88.9 x 76.1mm	157.0	105.0	88.9	76.1	20641
108 x 76.1mm	196.0	144.0	108.0	76.1	20642
108 x 88.9mm	192.0	133.0	108.0	88.9	20643

Connection: Male x Press

76.1mm - 108mm pending LPCB approval •Not LPCB approved

SC7 Straight connector

Size	A	Z	D	Order code
22mm x 1/2"	50.0	35.0	22.0	20256
22mm x 3/4"	53.0	36.7	22.0	20257

Connection: Male x BSP parallel female thread

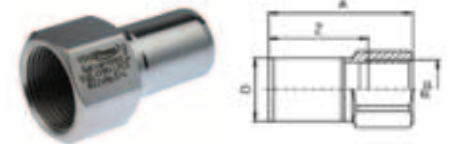

SC12 Elbow 90°

Size	L	Z	Order code
22mm	51.0	30.0	20157
28mm	60.0	37.0	20158
35mm	71.0	45.0	20159
42mm	86.0	56.0	20160
54mm	105.0	70.0	20161
76.1mm	150.0	95.0	20626
88.9mm	174.0	111.0	20627
108mm	215.0	139.0	20628

Connection: Press x Press

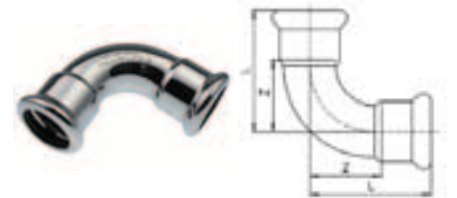

SC12S Street elbow 90°

Size	L	Z	h	Order code
22mm	51.0	30.0	58.1	20165
28mm	60.0	37.0	65.5	20166
35mm	71.0	45.0	75.9	20167
42mm	86.0	56.0	92.5	20168
54mm	105.0	70.0	110.6	20169
76.1mm	149.0	94.0	166.0	20629
88.9mm	172.0	109.0	190.0	20630
108mm	198.0	122.0	230.0	20631

Connection: Press x Male

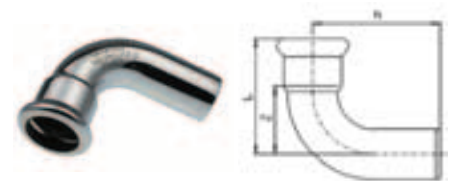

SC13 Elbow 90°

Size	B	Z	A	Order code
22mm x 3/4"	61.5	30.0	51.0	20201
28mm x 1"	73.5	37.0	60.0	20202
35mm x 1 1/4"	85.5	45.0	71.0	20206
42mm x 1 1/2"	95.5	56.0	86.0	20204
54mm x 2"	115.5	70.0	105.0	20205

Connection: Press x BSP taper male thread

76.1mm - 108mm pending LPCB approval

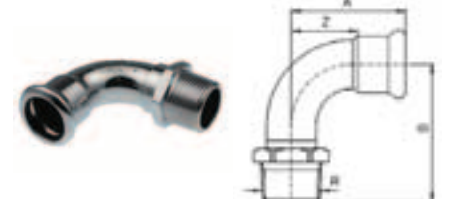

Galvanized sprinkler system

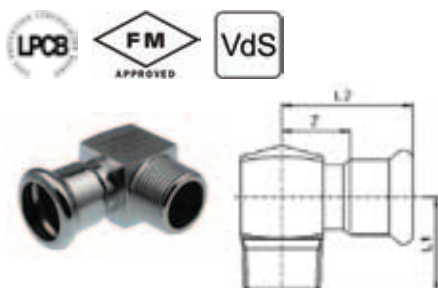

SC13A Angle adapter 90°

Size	L2	Z	L1	Order code
22mm x 3/4"	44.5	23.5	32.0	20208

Connection: Press x BSP taper male thread

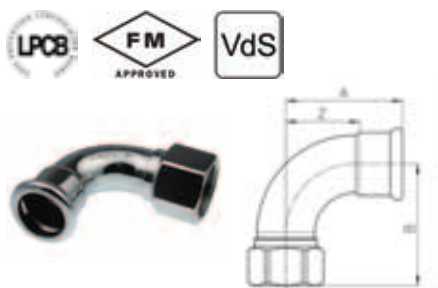

SC14 Elbow 90°

Size	B	Z	A	Order code
22mm x 1/2"	59.0	30.0	51.0	20345
22mm x 3/4"	59.0	30.0	51.0	20346
28mm x 1/2"	65.0	37.0	60.0	20347
28mm x 3/4"	65.0	37.0	60.0	20348
28mm x 1"	69.5	37.0	60.0	20349
35mm x 1/2"	74.5	45.0	71.0	20350
35mm x 3/4"	74.5	45.0	71.0	20351
35mm x 1"	74.5	45.0	71.0	20352

Connection: Press x BSP parallel female thread

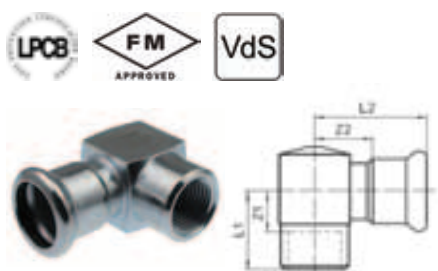

SC14A Angle adaptor 90°

Size	L1	L2	Z1	Z2	Order code
22mm x 1/2"	31.0	44.5	16.0	23.0	20355
28mm x 1/2"	35.0	50.5	20.0	26.7	20356
35mm x 1/2"	35.0	56.5	20.0	29.4	20357

Connection: Press x BSP parallel female thread

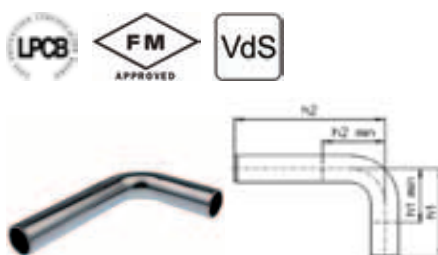

SC19S Elbow 90°

Size	h1	h1min	h2	h2min	Order code
22 x 22mm	72.0	70.0	120.0	70.0	20370
28 x 28mm	82.0	80.0	120.0	80.0	20371
35 x 35mm	120.0	100.0	200.0	100.0	20372
42 x 42mm	150.0	120.0	250.0	120.0	20373
54 x 54mm	200.0	145.0	300.0	145.0	20374

Connection: Male x male

76.1mm - 108mm pending LPCB approval

SC21 Obtuse elbow

Size	L	Z	Order code
22mm	35.2	14.2	20172
28mm	40.1	17.1	20173
35mm	46.4	20.4	20174
42mm	56.1	26.1	20175
54mm	66.9	31.9	20176
76.1mm	98.0	43.0	20632
88.9mm	113.0	50.0	20633
108mm	138.0	62.0	20634

Connection: Press x Press

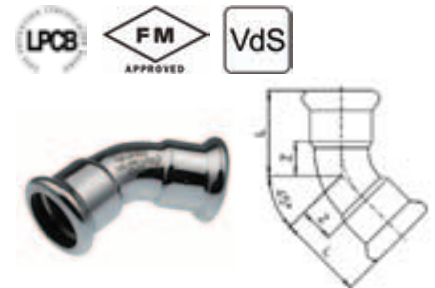

SC21S Obtuse street elbow

Size	L	Z	h	Order code
22mm	35.2	14.2	42.3	20179
28mm	40.1	17.1	45.6	20180
35mm	46.4	20.4	51.3	20181
42mm	56.1	26.1	62.6	20182
54mm	66.9	31.9	72.5	20183
76.1mm	96.0	41.0	119.0	20635
88.9mm	110.0	47.0	130.0	20636
108mm	137.0	61.0	160.0	20637

Connection: Press x Male

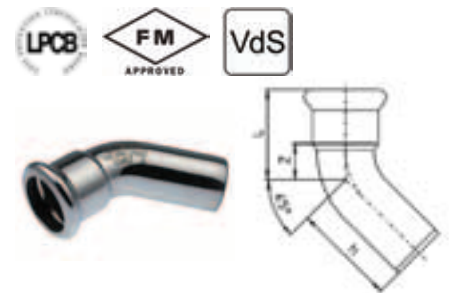

SC22S Crossover

Size	L	A	B	Order code
22mm	64.5	177.0	37.0	20195
28mm	75.0	215.0	43.0	20196

Connection: Male x Male

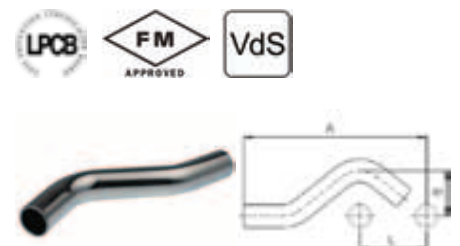

76.1mm - 108mm pending LPCB approval

Tee specification

See page 35

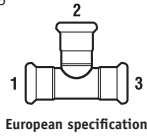
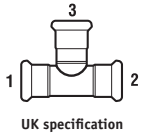

Galvanized sprinkler system

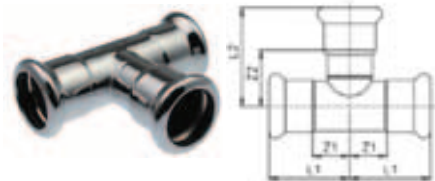

SC24 Equal tee

Size	L1	Z1	L2	Z2	Order code
22mm	39.5	18.5	48.5	27.5	20251
28mm	44.5	21.5	53.5	30.5	20252
35mm	51.0	25.0	60.0	34.0	20253
42mm	60.0	30.0	66.5	36.5	20254
54mm	71.0	36.0	77.5	42.5	20255
76.1mm	116.0	61.0	121.0	61.0	20644
88.9mm	131.0	68.0	126.0	63.0	20645
108mm	152.0	78.0	152.0	74.0	20646

Connection: Press all ends

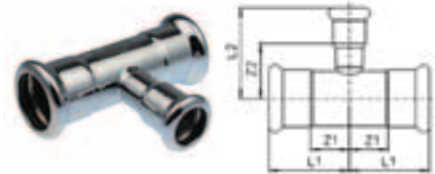

SC25 Tee reduced branch

Size	L1	Z1	L2	Z2	Order code
28 x 22mm	44.5	21.5	51.5	30.5	20264
35 x 22mm	51.0	25.0	55.0	34.0	20267
35 x 28mm	51.0	25.0	57.0	34.0	20268
42 x 22mm	60.0	30.0	57.5	36.5	20269
42 x 28mm	60.0	30.0	59.5	36.5	20270
42 x 35mm	60.0	30.0	62.5	36.5	20271
54 x 22mm	71.0	36.0	63.5	42.5	20272
54 x 28mm	71.0	36.0	65.5	42.5	20273
54 x 35mm	71.0	36.0	68.5	42.5	20274
54 x 42mm	71.0	36.0	72.5	42.5	20275
76.1 x 22mm	116.0	61.0	68.0	45.0	20686
76.1 x 28mm	116.0	61.0	71.0	47.0	20687
76.1 x 35mm	116.0	61.0	75.0	48.0	20688
76.1 x 42mm	116.0	61.0	79.0	47.0	20689
76.1 x 54mm	116.0	61.0	80.0	43.0	20647
88.9 x 22mm	131.0	68.0	76.0	53.0	20690
88.9 x 28mm	131.0	68.0	75.5	51.5	20691
88.9 x 35mm	131.0	68.0	83.0	56.5	20692
88.9 x 42mm	131.0	68.0	85.0	53.0	20693
88.9 x 54mm	131.0	68.0	92.5	55.5	20694
88.9 x 76.1mm	131.0	68.0	128.0	73.0	20648
108 x 22mm	156.0	78.0	85.0	62.0	20695
108 x 28mm	156.0	78.0	87.5	63.5	20696
108 x 35mm	156.0	78.0	93.5	66.0	20697
108 x 42mm	156.0	78.0	96.0	64.0	20698
108 x 54mm	156.0	78.0	102.0	65.0	20699
108 x 76.1mm	156.0	78.0	125.0	70.0	20700
108 x 88.9mm	156.0	78.0	135.0	72.0	20649

Connection: Press all ends

76.1mm - 108mm pending LPCB approval

Tee specification

See page 35

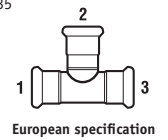
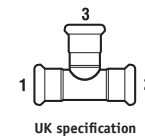

2

SC28 Tee both ends red

Size	L1	Z1	L2	Z2	Order code
22 x 22 x 28mm	39.5	18.5	52.0	29.0	20712

Connection: Press all ends

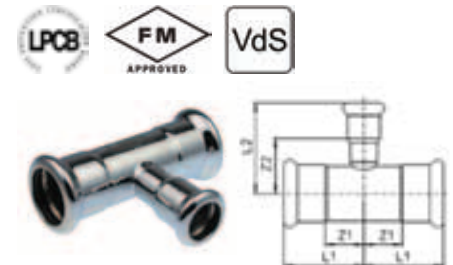

SC30 Female branch tee

Size	L1	Z1	L2	Z2	Order code
22mm x 1/2"	39.5	18.5	39.0	24.0	20283
22mm x 3/4"	39.5	18.5	41.0	24.7	20288
28mm x 1/2"	44.5	21.5	42.0	27.0	20284
28mm x 3/4"	44.5	21.5	44.0	27.7	20289
28mm x 1"	44.5	21.5	46.0	27.5	20279
35mm x 1/2"	51.0	25.0	45.5	30.5	20285
35mm x 3/4"	51.0	25.0	47.5	31.2	20290
35mm x 1"	51.0	25.0	50.0	31.0	20280
42mm x 1/2"	60.0	30.0	48.0	33.0	20286
42mm x 3/4"	60.0	30.0	50.0	33.7	20291
42mm x 1"	60.0	30.0	52.5	33.5	20294
54mm x 1/2"	71.0	36.0	54.0	39.0	20287
54mm x 3/4"	71.0	36.0	56.0	39.7	20292
54mm x 1"	71.0	36.0	60.0	41.0	20293
76.1mm x 3/4"	116.0	61.0	69.0	52.0	20650
88.9mm x 3/4"	131.0	68.0	76.0	59.0	20651
108mm x 3/4"	156.0	78.0	86.0	69.0	20652

Connection: Press x BSP parallel female thread

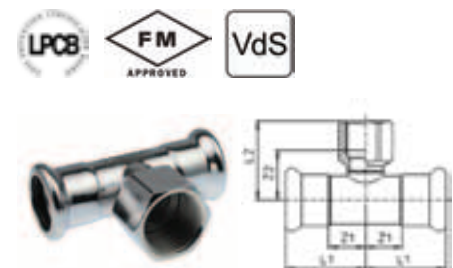

SC50 Cross

Size	L1	Z1	L2	Z2	Order code
35mm	51.5	25.3	60.0	33.8	20327
42mm	60.7	30.4	66.5	36.3	20328
54mm	71.0	36.0	77.5	42.5	20329
35 x 28mm	51.5	25.3	57.0	33.7	20334
42 x 28mm	60.7	30.4	59.5	36.2	20335
54 x 28mm	71.0	36.0	65.5	42.2	20336

Connection: Press all ends



76.1mm - 108mm pending LPCB approval

Galvanized sprinkler system

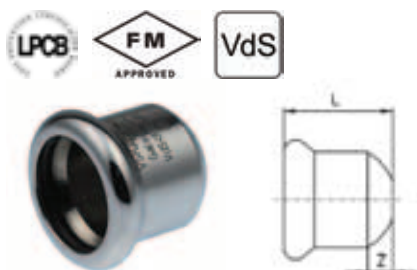

SC61 Stop end

Size	L	Z	Order code
22mm	28.5	7.5	20297
28mm	32.3	9.3	20298
35mm	34.4	8.4	20299
42mm	43.2	13.2	20300
54mm	51.8	16.8	20301
76.1mm	70.0	15.0	20656
88.9mm	87.0	24.0	20657
108mm	98.0	21.0	20658

Connection: Press

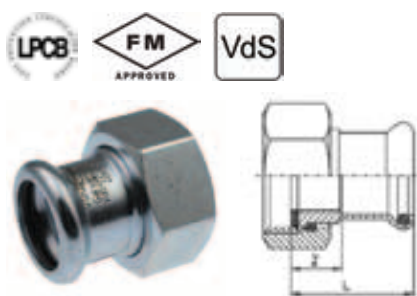

SC68FF Half union

Size	L	Z	Order code
22mm x 1"	32.0	11.0	20337
28mm x 1 ¹ / ₄ "	33.0	10.0	20338
35mm x 1 ¹ / ₂ "	36.0	10.0	20339
42mm x 1 ³ / ₄ "	43.0	13.0	20340
54mm x 2 ³ / ₈ "	50.0	15.0	20341

Connection: Press x BSP female union end

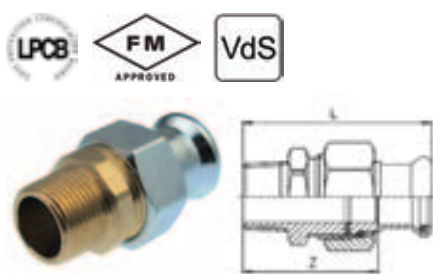

SC69 Straight male union

Size	L	Z	Order code
22mm x ³ / ₄ "	70.0	49.0	20307
28mm x 1"	74.7	51.7	20309
35mm x 1 ¹ / ₄ "	81.8	55.8	20310
42mm x 1 ¹ / ₂ "	88.0	58.0	20311
54mm x 2"	100.0	65.0	20312

Connection: Press x BSP taper male thread

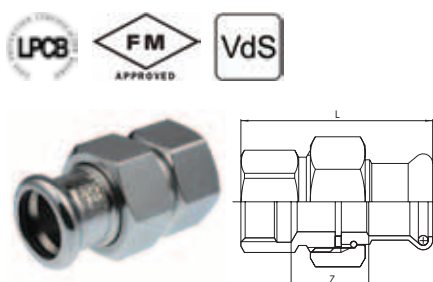

SC69F Straight female union connector

Size	L	Z	Order code
22mm x ³ / ₄ "	63.0	22.0	20317
28mm x 1"	65.0	19.0	20319
35mm x 1 ¹ / ₄ "	75.5	24.5	20320
42mm x 1 ¹ / ₂ "	82.5	27.5	20321
54mm x 2"	92.5	28.0	20322

Connection: Press x BSP parallel female thread

76.1mm - 108mm pending LPCB approval

Stainless steel sprinkler system

SS600 316 System tube 1.4401

Size	Order code
22mm x 1.2mm x 6m	25052
28mm x 1.2mm x 6m	25053
35mm x 1.5mm x 6m	25054
42mm x 1.5mm x 6m	25055
54mm x 1.5mm x 6m	25056

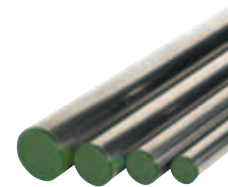

SS620 316 System tube 1.4401

Size	Order code
76.1mm x 2.0mm x 6m	25026
88.9mm x 2.0mm x 6m	25028
108mm x 2.0mm x 6m	25030

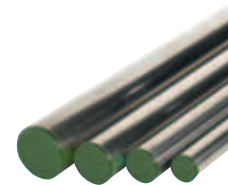

SS630 444 System tube 1.4521

Size	Order code
22mm x 1.2mm x 6m	25072
28mm x 1.2mm x 6m	25073
35mm x 1.5mm x 6m	25074
42mm x 1.5mm x 6m	25075
54mm x 1.5mm x 6m	25076



SS640 439 System tube 1.4520

Size	Order code
22mm x 1.2mm x 6m	25067
28mm x 1.2mm x 6m	25068
35mm x 1.5mm x 6m	25069
42mm x 1.5mm x 6m	25070
54mm x 1.5mm x 6m	25071

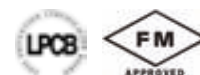

76.1mm - 108mm pending LPCB approval

Stainless steel sprinkler system

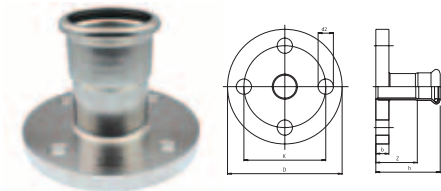

SS1FMF Flanged connector PN10/16

Size	Z	D	d2	H	K	B	Order code
22mm	42.5	105.0	14.0	63.5	75.0	12.0	11570
28mm	48.0	115.0	14.0	71.0	85.0	14.0	11571
35mm	53.0	140.0	18.0	79.0	100.0	15.0	11572
42mm	61.0	150.0	18.0	91.0	110.0	16.0	11680
54mm	77.0	165.0	18.0	112.0	125.0	18.0	11681
76.1mm	71.0	185.0	18.0	126.0	145.0	18.0	20412
88.9mm	84.0	200.0	18.0	147.0	160.0	20.0	20413
108mm	90.0	220.0	18.0	167.0	180.0	20.0	20414

Connection: Press x Flange

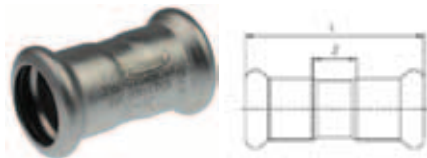

SS1 Straight coupling

Size	L	Z	Order code
22mm	52.0	10.0	11696
28mm	56.2	10.2	11697
35mm	62.3	10.3	11698
42mm	73.3	13.3	11699
54mm	83.0	13.0	11700
76.1mm	142.0	32.0	20415
88.9mm	163.0	37.0	20416
108mm	192.0	38.0	20417

Connection: Press x Press



SS1SLIP Slip coupling

Size	L	es	Order code
22mm	84.0	21.0	11729
28mm	91.2	23.0	11731
35mm	102.2	26.0	11732
42mm	120.3	30.0	11733
54mm	140.0	35.0	11734
76.1mm	230.0	60.0	20428
88.9mm	258.0	70.0	20429
108mm	305.0	80.0	20430

Connection: Press x Press

76.1mm - 108mm pending LPCB approval

SS1V Transition for grooved couplings

Size	L	D	Z	Order code
28 x 33.7mm	72.5	33.7	26.0	11675
35 x 42.4mm	81.0	42.4	26.0	11676
42 x 48.3mm	86.0	48.3	26.0	11677
54 x 60.3mm	96.5	60.3	26.0	11678
76.1 x 76.1mm	90.0	76.1	36.0	20461
88.9 x 88.9mm	100.0	88.9	36.0	20462
108 x 114.4mm	110.0	114.3	36.0	20463

Connection: Press x Groove

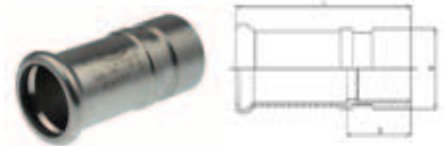

SS2 Straight connector

Size	L	Z	Order code
22mm x 1/2"	36.5	5.5	11646
22mm x 3/4"	39.5	7.5	11647
22mm x 1"	43.6	9.6	11649
28mm x 1/2"	38.0	4.5	11631
28mm x 3/4"	40.0	6.0	11650
28mm x 1"	44.6	8.6	11648
28mm x 1 1/4"	47.0	9.0	11651
35mm x 1"	46.0	7.0	11652
35mm x 1 1/4"	50.0	9.0	11653
35mm x 1 1/2"	50.0	10.0	11632
42mm x 1 1/4"	52.0	3.0	11655
42mm x 1 1/2"	54.0	10.0	11654
54mm x 1 1/2"	58.0	9.0	11633
54mm x 2"	63.0	10.0	11657

Connection: Press x BSP parallel female thread

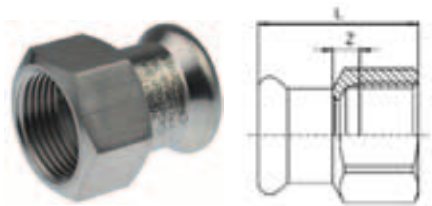

SS2LC Slip long coupling

Size	A	B	C	ΔL	Order code
22mm x 1/2"	92.0	25.0	15.0	40.0	11590
22mm x 3/4"	97.0	25.0	16.0	40.0	11591
28mm x 1/2"	94.0	30.0	15.0	40.0	11592
28mm x 3/4"	93.0	30.0	16.0	40.0	11593

Connection: Press x BSP parallel female thread

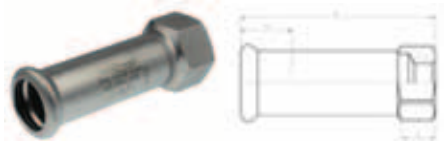

76.1mm - 108mm pending LPCB approval

Stainless steel sprinkler system

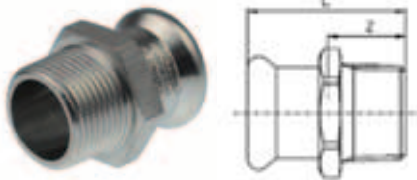

SS3 Straight connector

Size	L	Z	Order code
22mm x 1/2"	42.0	21.0	11662
22mm x 3/4"	43.3	22.3	11664
22mm x 1"	48.5	27.5	11663
28mm x 3/4"	45.2	22.2	11642
28mm x 1"	48.0	25.0	11665
28mm x 1 1/4"	51.5	28.5	11666
35mm x 1"	52.7	26.7	11667
35mm x 1 1/4"	55.0	29.0	11670
35mm x 1 1/2"	56.0	30.0	11645
42mm x 1 1/4"	59.0	29.0	11668
42mm x 1 1/2"	59.0	29.0	11671
54mm x 1 1/2"	64.7	29.7	11656
54mm x 2"	69.0	34.0	11674
76.1mm x 2 1/2"	125.0	70.0	20458
88.9mm x 3"	138.0	75.0	20459

Connection: Press x BSP taper male thread

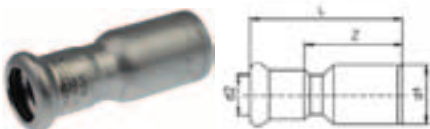

SS6 Reducer

Size	L	Z	Order code
28 x 22mm	61.2	40.2	11717
35 x 22mm	69.0	48.0	11719
35 x 28mm	68.1	45.1	11720
42 x 22mm•	84.5	63.5	11659
42 x 28mm	77.9	54.9	11722
42 x 35mm	77.6	51.6	11723
54 x 22mm•	96.5	75.5	11724
54 x 28mm•	95.5	72.5	11725
54 x 35mm	94.6	68.6	11726
54 x 42mm	95.1	65.1	11727
76.1 x 42mm	151.0	119.0	20460
76.1 x 54mm	140.0	103.0	20422
88.9 x 54mm	156.0	119.0	20423
88.9 x 76.1mm	156.0	101.0	20424
108 x 54mm	204.0	167.0	20425
108 x 76.1mm	196.0	141.0	20426
108 x 88.9mm	190.0	127.0	20427

Connection: Press x Male

76.1mm - 108mm pending LPCB approval •Not LPCB approved

SS12 Elbow 90°

Size	L	Z	Order code
22mm	51.0	30.0	11622
28mm	60.1	37.1	11623
35mm	71.1	45.1	11624
42mm	86.1	56.1	11625
54mm	105.0	70.0	11626
76.1mm	150.0	95.0	20406
88.9mm	175.0	112.0	20407
108mm	214.0	137.0	20408

Connection: Press x Press

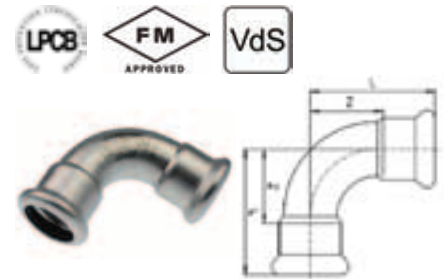
**SS12S Street elbow 90°**

Size	L	Z	h	Order code
22mm	51.0	30.0	60.0	11636
28mm	60.1	37.1	65.5	11637
35mm	71.1	45.1	75.9	11638
42mm	86.1	56.1	92.5	11639
54mm	105.0	70.0	110.6	11640
76.1mm	150.0	95.0	165.0	20409
88.9mm	174.0	112.0	190.0	20410
108mm	216.0	137.0	238.0	20411

Connection: Press x Male

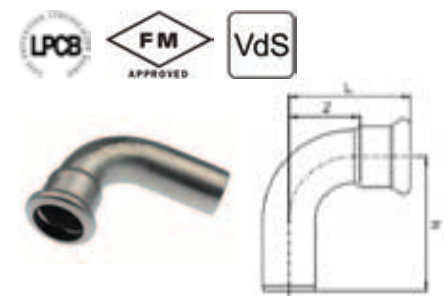
**SS13 Male elbow**

Size	L2	Z	L1	Order code
22mm x 3/4"	48.5	27.5	38.5	11689
28mm x 1"	53.0	30.0	46.0	11690
35mm x 1 1/4"	60.0	34.0	52.0	11691
42mm x 1 1/2"	69.0	39.0	58.0	11692
54mm x 2"	82.0	47.0	68.0	11693

Connection: Press x BSP taper male thread

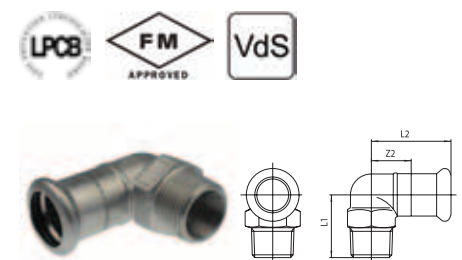

76.1mm - 108mm pending LPCB approval

Stainless steel sprinkler system



SS14 Female elbow

Size	L2	Z2	L1	Z1	Order code
22mm x 1/2"	45.0	24.0	31.0	16.0	11683
22mm x 3/4"	48.5	27.5	33.0	16.7	11684
28mm x 1/2"	47.5	24.5	35.0	16.0	11600
28mm x 3/4"	50.5	27.5	35.0	18.5	11601
28mm x 1"	54.5	31.5	37.0	17.5	11685
35mm x 1/2"	56.0	30.0	35.0	20.0	11602
35mm x 3/4"	57.5	31.5	37.0	21.0	11603
35mm x 1"	58.0	32.0	40.5	21.0	11669
35mm x 1 1/4"	62.0	36.0	42.2	20.5	11686

Connection: Press x BSP parallel female thread

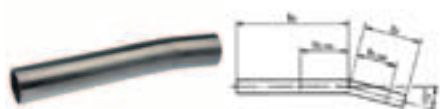

SS19S 15° degree bend

Size	h2	h2min	h1	h1min	Order code
28mm	134.0	45.0	45.0	45.0	11550
35mm	222.0	53.0	73.0	53.0	11551
42mm	280.0	59.0	89.0	59.0	11552
54mm	337.0	67.0	122.0	67.0	11553

Connection: Male x Male



SS19S 30° degree bend

Size	h2	h2min	h1	h1min	Order code
28mm	130.0	51.0	51.0	51.0	11554
35mm	214.0	60.0	73.0	60.0	11795
42mm	272.0	69.0	99.0	69.0	11796
54mm	326.0	79.0	134.0	79.0	11797

Connection: Male x Male

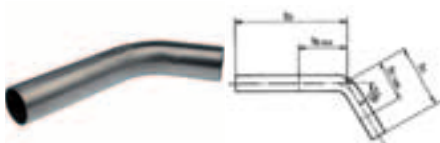

SS19S 60° degree bend

Size	h2	h2min	h1	h1min	Order code
28mm	121.0	63.0	63.0	63.0	11555
35mm	203.0	77.0	97.0	77.0	11556
42mm	256.0	90.0	120.0	90.0	11557
54mm	306.0	107.0	162.0	107.0	11558

Connection: Male x Male

76.1mm - 108mm pending LPCB approval

SS19S 90° degree bend

Size	h2	h2min	h1	h1min	Order code
22mm	120.0	70.0	72.0	70.0	11561
28mm	120.0	80.0	82.0	80.0	11562
35mm	200.0	100.0	120.0	100.0	11563
42mm	250.0	120.0	150.0	120.0	11564
54mm	300.0	145.0	200.0	145.0	11565

Connection: Male x Male

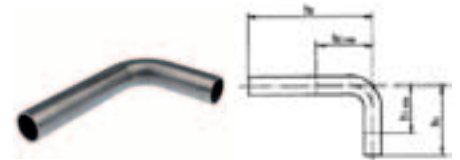

SS21 Obtuse elbow

Size	L	Z	Order code
22mm	35.2	14.2	11606
28mm	40.2	17.2	11607
35mm	46.5	20.5	11608
42mm	56.3	26.3	11609
54mm	66.9	31.9	11610
76.1mm	98.0	43.0	20400
88.9mm	112.0	49.0	20401
108mm	138.0	61.0	20402

Connection: Press x Press



SS21S Obtuse street elbow

Size	L	Z	H	Order code
22mm	35.2	14.2	42.3	11613
28mm	40.2	17.2	45.6	11614
35mm	46.5	20.5	51.3	11615
42mm	56.3	26.3	62.6	11616
54mm	66.9	31.9	72.5	11617
76.1mm	98.0	43.0	117.0	20403
88.9mm	112.0	49.0	131.0	20404
108mm	138.0	61.0	154.0	20405

Connection: Press x Male



SS22S Crossover

Size	A	B	L	Order code
22mm	178.0	44.0	65.0	11618
28mm	210.0	50.0	74.0	11619

Connection: Male x Male



76.1mm - 108mm pending LPCB approval

Tee specification

See page 35

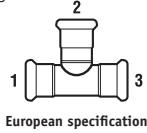
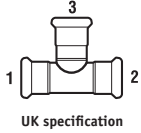

Stainless steel sprinkler system



SS24 Equal tee

Size	L1	Z1	L2	Z2	Order code
22mm	39.5	18.5	43.5	22.5	11740
28mm	44.5	21.5	48.5	25.5	11744
35mm	51.0	25.0	55.0	29.0	11749
42mm	60.0	30.0	61.5	31.5	11753
54mm	71.0	36.0	72.5	37.5	11758
76.1mm	116.0	61.0	115.0	60.0	20431
88.9mm	131.0	68.0	127.0	64.0	20432
108mm	156.0	79.0	155.0	78.0	20433

Connection: All press ends

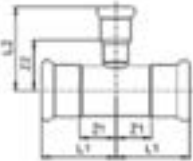

SS25 Tee reduced branch

Size	L1	Z1	L2	Z2	Order code
28mm x 22mm	44.5	21.5	46.5	25.5	11743
35mm x 22mm	51.0	25.0	50.0	29.0	11747
35mm x 28mm	51.0	25.0	52.0	29.0	11748
42mm x 22mm	60.0	30.0	52.5	31.5	11750
42mm x 28mm	60.0	30.0	54.5	31.5	11751
42mm x 35mm	60.0	30.0	57.5	31.5	11752
54mm x 22mm	71.0	36.0	58.5	37.5	11754
54mm x 28mm	71.0	36.0	60.5	37.5	11755
54mm x 35mm	71.0	36.0	63.5	37.5	11756
54mm x 42mm	71.0	36.0	67.5	37.5	11757
76.1mm x 22mm	116.0	61.0	68.0	45.0	20434
76.1mm x 28mm	116.0	61.0	71.0	47.0	20435
76.1mm x 35mm	116.0	61.0	75.0	48.0	20436
76.1mm x 42mm	116.0	61.0	79.0	47.0	20437
76.1mm x 54mm	116.0	61.0	80.0	43.0	20438
88.9mm x 22mm	131.0	68.0	76.0	53.0	20439
88.9mm x 28mm	131.0	68.0	76.0	52.0	20440
88.9mm x 35mm	131.0	68.0	83.0	56.0	20441
88.9mm x 42mm	131.0	68.0	85.0	53.0	20442
88.9mm x 54mm	131.0	68.0	93.0	56.0	20443
88.9mm x 76.1mm	131.0	68.0	116.0	61.0	20444
108mm x 22mm	156.0	79.0	85.0	62.0	20445
108mm x 28mm	156.0	79.0	88.0	64.0	20446
108mm x 35mm	156.0	79.0	94.0	67.0	20447
108mm x 42mm	156.0	79.0	96.0	64.0	20448
108mm x 54mm	156.0	79.0	102.0	65.0	20449
108mm x 76.1mm	156.0	79.0	125.0	70.0	20450
108mm x 88.9mm	156.0	79.0	135.0	72.0	20451

Connection: All press ends

76.1mm - 108mm pending LPCB approval

Tee specification

See page 35

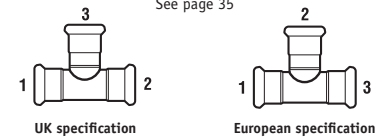

2

SS30 Female branch tee

Size	L1	Z1	L2	Z2	Order code
22mm x 1/2"	39.5	18.5	39.0	22.0	11762
22mm x 3/4"	39.5	18.5	41.0	23.0	11763
28mm x 1/2"	44.5	21.5	42.0	25.0	11765
28mm x 3/4"	44.5	21.5	44.0	26.0	11766
28mm x 1"	44.5	21.5	46.0	27.5	11627
35mm x 1/2"	51.0	25.0	45.5	28.5	11767
35mm x 3/4"	51.0	25.0	47.5	29.5	11768
35mm x 1"	51.0	25.0	50.0	31.0	11628
42mm x 1/2"	60.0	30.0	48.0	31.0	11769
42mm x 3/4"	60.0	30.0	50.0	32.0	11770
42mm x 1"	60.0	30.0	52.5	33.5	11629
54mm x 1/2"	71.0	36.0	54.0	37.0	11771
54mm x 3/4"	71.0	36.0	56.0	38.0	11773
54mm x 1"	71.0	36.0	58.0	39.0	11630
54mm x 2"	71.0	36.0	64.7	46.7	11772
76.1mm x 3/4"	116.0	55.0	68.0	55.0	20452
76.1mm x 2"	116.0	55.0	81.0	59.0	20453
88.9mm x 3/4"	131.0	63.0	87.0	74.0	20454
88.9mm x 2"	131.0	63.0	88.0	66.0	20455
108mm x 3/4"	156.0	77.0	86.0	73.0	20456
108mm x 2"	156.0	77.0	98.0	76.0	20457

Connection: Press x BSP parallel female thread



SS61 Stop end

Size	L	Z	Order code
22mm	24.1	3.1	11703
28mm	26.1	3.1	11704
35mm	29.1	3.1	11705
42mm	36.1	6.6	11706
54mm	41.6	6.6	11707
76.1mm	95.0	40.0	20418
88.9mm	107.0	44.0	20419
108mm	127.0	50.0	20420

Connection: Press

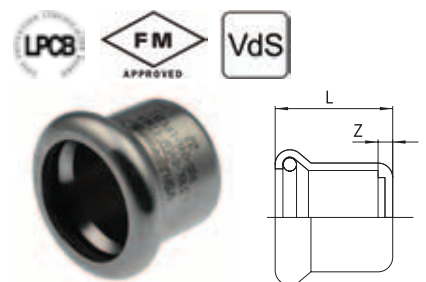

76.1mm - 108mm pending LPCB approval

Stainless steel sprinkler system

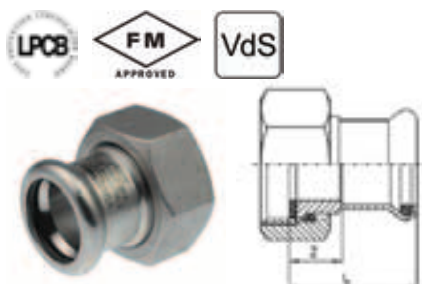

SS68FF Union

Size	L	Z	Order code
22mm x 1"	32.0	11.0	11891
28mm x 1 ¹ / ₄ "	33.0	10.0	11892
35mm x 1 ¹ / ₂ "	36.0	10.0	11893
42mm x 1 ³ / ₄ "	43.0	13.0	11894
54mm x 2 ³ / ₈ "	50.0	15.0	11895

Connection: Press x BSP female union end



SS69 Straight male union connector

Size	L	Z	Order code
22mm x 1/2"	63.0	42.0	11721
22mm x 3/4"	68.5	47.5	11779
22mm x 1"	71.8	50.8	11764
28mm x 1"	72.8	49.8	11781
35mm x 1 ¹ / ₄ "	78.2	52.2	11782
42mm x 1 ¹ / ₂ "	85.4	55.4	11783
54mm x 2"	100.0	65.0	11784

Connection: Press x BSP taper male thread

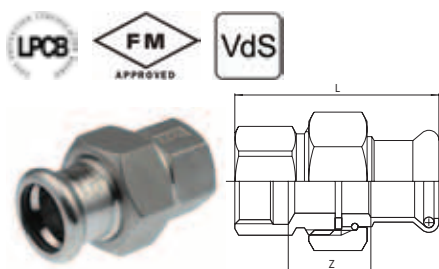

SS69F Straight female union connector

Size	L	Z	Order code
22mm x 3/4"	63.0	25.5	11789
22mm x 1"	65.8	25.3	11798
28mm x 1"	65.0	22.5	11791
35mm x 1 ¹ / ₄ "	73.0	25.3	11792
42mm x 1 ¹ / ₂ "	82.0	30.0	11793
54mm x 2"	91.0	30.0	11794

Connection: Press x BSP parallel female thread

76.1mm - 108mm pending LPCB approval

SS80 Straight flexible hoses

Size	L	Order code
22mm x 1/2"	1000	11575
22mm x 1/2"	1500	11576
22mm x 1/2"	2000	11577
28mm x 1/2"	1000	11578
28mm x 1/2"	1500	11579
28mm x 1/2"	2000	11580

All flexible hoses are supplied including universal mounting bracket, square pipe 700mm, moveable sprinkler clamp (closed), multiclips x 2 with BSP parallel female thread



SS82 90° Flexible hoses

Size	L	Order code
22mm x 1/2"	800	11581
22mm x 1/2"	1000	11582
22mm x 1/2"	1500	11583
28mm x 1/2"	800	11584
28mm x 1/2"	1000	11585
28mm x 1/2"	1500	11586

All flexible hoses are supplied including universal mounting bracket, square pipe 700mm, moveable sprinkler clamp (closed), multiclips x 2 with BSP parallel female thread



XPress accessories



SS100 'O' Ring leak before press

Size	Order code
22mm	27002
28mm	27003
35mm	27004
42mm	27005
54mm	27006
76.1mm	27007
88.9mm	27008
108mm	27009

Connection: Black EPDM

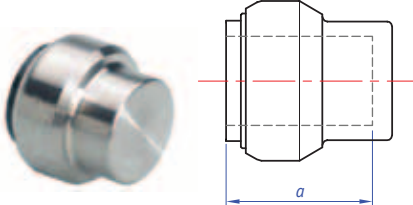

TS61 Stop end

Size	a	Order code
22mm	29	25874
28mm	34	25876
35mm	57	25878
42mm	62	25880
54mm	69	25882

Connection: Push-fit



S110 Depth gauge

Suitable for carbon and stainless steel

Size	Order code
15 - 54mm	39160

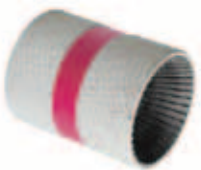

S120 Deburring tool

Size	Order code
15 - 54mm	39168

TX100 Replacement 'O' ring

Size	Order code
35mm	46147
42mm	46148
54mm	46149



For use with Tectite only

TX106 Replacement grab ring for Tectite 316

Size	Order code
35mm	46183
42mm	46184
54mm	46185



DC Disconnecting clip

Size	Order code
22mm	46107
28mm	46108



DTX Disconnecting tool

Size	Order code
35 - 54mm	46145



Fixed fire sprinkler systems

Fixed sprinkler systems are permanently installed fire suppressing and fire protection systems, which independently detect and report a fire and automatically start the suppressing process. The installation of the XPress sprinkler system in sprinkler systems is carried out in accordance with appropriate guidelines e.g. VdS-CEA 4001, EN 12845 or NFPA/FM.

XPress Galvanised Sprinkler system tube can only be used in a sprinkler installation and should not be used in general plumbing application. XPress sprinkler Galvanized is only suitable for use in fixed wet sprinkler systems, where XPress sprinkler Stainless can be used in both wet and dry fixed sprinkler systems depending on the approval.

With different approvals under which the XPress sprinkler system is installed, also different hazard classes may apply. For more detailed information on applicable hazard classes, please contact Pegler Yorkshire directly.

When the XPress sprinkler system is used, it should also be ensured that no loads can fall onto the tube network under normal conditions or in the case of a fire; for example ventilation ducts and cable trays should not be installed above the sprinkler tubes. If due to building constraints loads could fall onto the tube network this can be solved by securing the sprinkler tube on both sides of the load with sprinkler certified components.

Depending on your type of system and the approval which applies to your fixed sprinkler system, different fastener distances apply. In VdS sprinkler applications the fastener distances for steel press systems are based on the values used for copper tube, where FM and LPCB have specific fastener distances prescribed for XPress. Always follow the valid local guidelines and please make sure to follow these fastener distances correctly. Make sure to use the appropriate hangers for sprinkler applications which are also suitable for the outside diameters of XPress sprinkler and that no hangers are mounted on the fittings.

Fastener distances for XPress sprinkler tubes

DN	Tube dimension	Fastener distances (m)			
		CEA 4001 (vdS)	NFPA 13	LPCB	DIN 1988-2
20	22	2.00	3.66	2.50	2.00
25	28	2.00	3.66	2.50	2.25
32	35	2.00	3.66	3.50	2.75
40	42	2.00	3.66	3.50	3.00
50	54	2.00	3.66	3.50	3.50
65	76.1	2.00	3.66	-	4.25
80	88.9	2.00	3.66	-	4.75
100	108	2.00	3.66	-	5.00

XPress sprinkler stainless is the preferred solution when looking to sprinkler installations which are installed in an aggressive environment such as for example

paper factories or where high standards apply on hygiene such as pharma and food and beverage. Combined with the ship building approvals Germanischer Loyds,

RINA and Det Norske Veritas XPress sprinkler stainless is also a very suitable solution for sprinkler installations on ships.

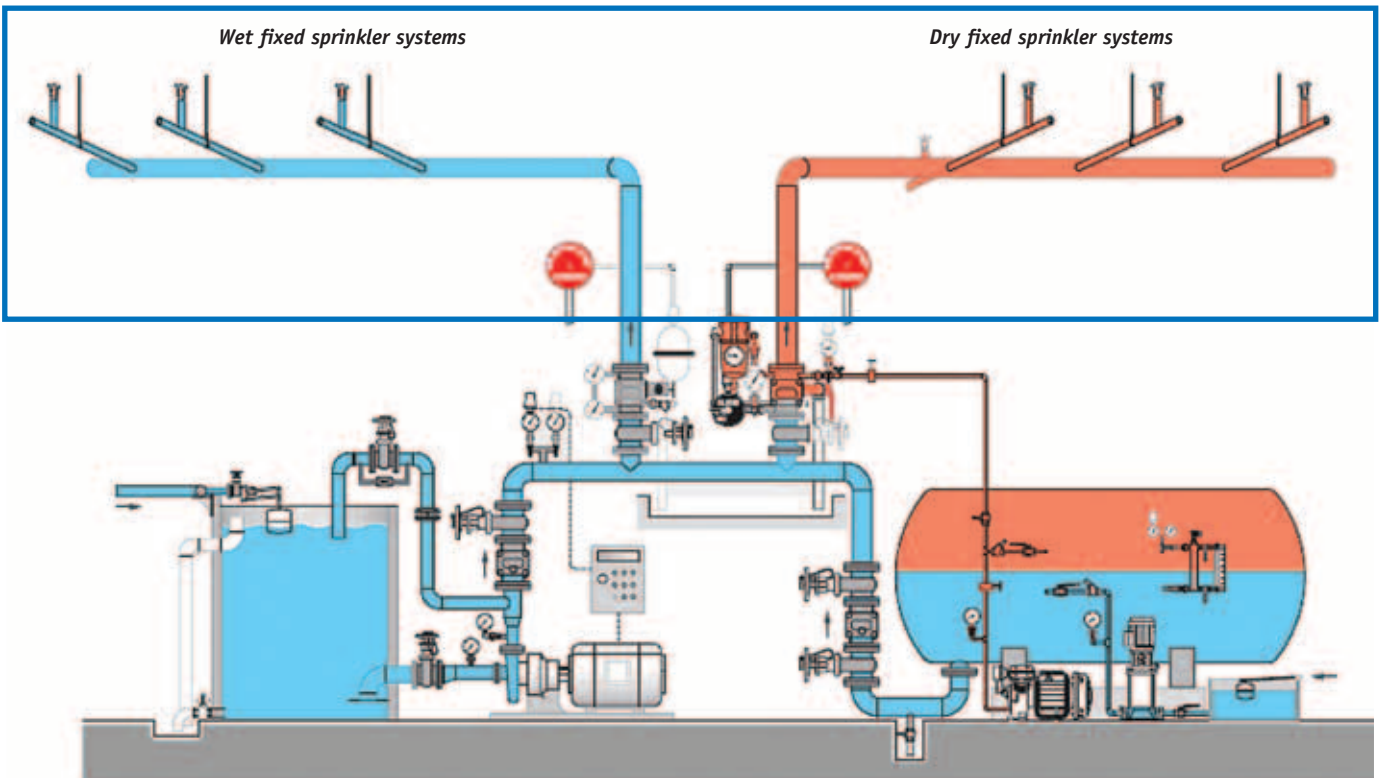
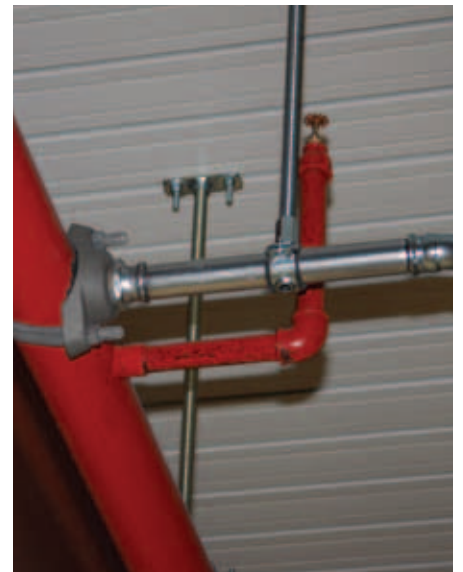

XPress flexible hoses

The lining up of sprinklers using rigid piping in suspended ceiling systems can be very time consuming and costly. The use of XPress flexible hoses for sprinkler installations enables a quick and easy connection of sprinkler heads within a circular area defined by the hose length. With the flexible sprinkler hoses it is possible to mount sprinklers in suspended ceilings systems without any problems, resulting in significant time and cost savings.



The supplied mounting brackets ensure a reliable and secure attachment of the sprinkler hose to the ceiling system substructure.

The XPress flexible hoses are part of the XPress Sprinkler VdS approval for fixed sprinkler installations. Pegler Yorkshire can offer you 2 versions, either with a straight end or an angle of 90°. Available dimensions are DN20 and DN25 in the lengths 800, 1000, 1500 and 2000mm.

Application

The XPress flexible hoses are suitable to be installed in:

- I-beam lay-in ceiling systems with mineral fibre panels and metal cassettes (main and ancillary profiles)
- Clamping profile ceiling systems
- Plasterboard ceiling systems
- Suspension-mounted standard sprinklers
- Hidden or recessed sprinklers

The special feature of these hoses is the straight pipe which is 100% compatible to the XPress Sprinkler system. The straight pipe end assures an easy connection from the flexible hose to the XPress Sprinkler systems. Where with threaded connections the whole hose needs to be rotated, with the straight pipe end you only need to position the pipe end in the fitting and you are ready for pressing.

Advantages

The XPress flexible hoses are suitable to be installed in:

- Simple and quick installation with the flexible sprinkler hose using standard tooling
- Entire sprinkler hose is made of stainless steel
- Easy bypass of other parts and building components
- No rotation of complete hose during installation because of straight pipe end
- Flexibility of positioning the sprinkler mounting system across the ceiling panel
- No bending or lifting of ceiling elements as sprinkler hose is fixed on ceiling substructure
- Where leaks on rigid piping systems can only be detected when the ceiling panels have already been installed, leaks on sprinkler systems equipped with flexible hose are already detected in building shells. Expensive water damage can thus be prevented
- The sprinkler system does not need to be reinstalled for renovation or conversion. Hoses and brackets can be dismantled and remounted at the new location without emptying the complete installation, within the circular area defined by the hose length
- Easy vertical positioning due to scaling on sprinkler sleeve

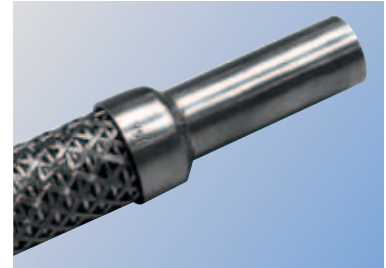

Flexible sprinkler hoses suitable for XPress sprinkler; flexible, simple, secure and cost saving

Length (mm)	Sprinkler discharge	Sprinkler connection	Pipe conn. (mm)	Press. loss* (bar)	Equiv. pipe length* (m)
1000	straight	Rp 1/2"	Ø22	0.9	8
1500	straight	Rp 1/2"	Ø22	1.3	12
2000	straight	Rp 1/2"	Ø22	1.7	14
1000	straight	Rp 1/2"	Ø28	0.5	8
1500	straight	Rp 1/2"	Ø28	0.8	11
2000	straight	Rp 1/2"	Ø28	1.0	12
800	90° angle	Rp 1/2"	Ø22	0.8	8
1000	90° angle	Rp 1/2"	Ø22	0.9	8
1500	90° angle	Rp 1/2"	Ø22	1.3	12
800	90° angle	Rp 1/2"	Ø28	0.5	8
1000	90° angle	Rp 1/2"	Ø28	0.5	8
1500	90° angle	Rp 1/2"	Ø28	0.8	11

*Pressure losses and equivalent pipe lengths correspond with VdS specifications

'O' ring

The XPress sprinkler fittings are supplied with an EPDM 'O' ring with the following data:

	LBP EPDM 'O' ring (DN20-DN50)	EPDM 'O' ring (DN65-DN100)
Material	EPDM	EPDM
Colour	Black	Black
Coating	Silicone-free	Silicone-free
Min./max. temperature (°C)	-35°C up to +135°C	-35°C up to +135°C
Max. short-term operating temperature (°C)	150°C	150°C
Max. operating pressure (bar)	16 bar*	16 bar*
Fields of operation	Wet and dry tube sprinkler systems	Wet and dry tube sprinkler systems

*Refer to working pressures table for applicable dimensions

Threaded couplings

The XPress sprinkler product range also comprises articles with internal and external thread for connection with other threaded parts of a tube network (for example sprinklers, valves, mountings). Internal and external threads are produced in accordance with DIN 2999/ISO 7/1.

Teflon® may be used as sealing material for the carbon steel threads. Only industry standard chloride free sealants should be used to seal the thread connections in the case of stainless steel fittings. Teflon® thread sealing band cannot be used in conjunction with stainless steel due to water-soluble chloride ions contained therein. For threaded connections we recommend that the pressed connections are not be subjected to a load.

Connectors

Male connectors

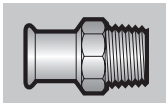

XPress male connectors have threads to BS 21/

ISO 7/EN 10226-1. Inert jointing compounds or PTFE tape should be applied to taper threads and good quality jointing washers should be used with parallel threaded fittings.

PTFE tape should not be used in conjunction with stainless steel threads due to the water soluble chloride ions it contains.

Female connectors

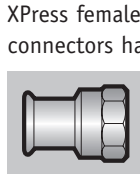

XPress female threaded connectors have internal parallel threads to ISO 7/EN 10226-1.

Tee specification

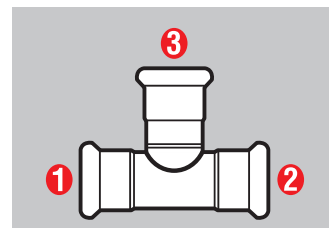

UK specification

First quote the ends on the run (larger end first) and then the branches.

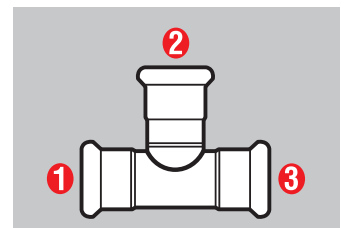

European specification

Quote the larger end first, then the branch, followed by the remaining end.

Dimensions of XPress Sprinkler Galvanized tube

DN	Nominal width (mm)	Wall thickness (mm)	Wall thickness tolerance (mm)	Weight (kg)	Capacity (l/m)
20	22	1.5	±0.15	0.761	0.284
25	28	1.5	±0.15	0.980	0.491
32	35	1.5	±0.15	1.241	0.804
40	42	1.5	±0.15	1.542	1.195
50	54	1.5	±0.15	1.999	2.043
65	76.1*	2.0	±0.20	3.503	4.083
80	88.9*	2.0	±0.20	4.412	5.661
100	108*	2.0	±0.20	5.382	8.495

Dimensions of XPress 316 System tube

DN	Nominal width (mm)	Wall thickness (mm)	Wall thickness tolerance (mm)	Weight (kg)	Capacity (l/m)
20	22	1.2	±0.10	0.624	0.302
25	28	1.2	±0.10	0.990	0.515
32	35	1.5	±0.10	1.240	0.804
40	42	1.5	±0.10	1.503	1.195
50	54	1.5	±0.10	1.972	2.043
65	76.1*	2.0	±0.15	3.550	4.548
80	88.9*	2.0	±0.15	4.150	5.661
100	108*	2.0	±0.15	5.050	8.495

Material specifications of XPress Sprinkler Galvanized tube

Material	Unalloyed ULC ('Ultra Light Carbon') C-steel, E190 part no. 1.0031 according EN 10305-3
Specifications	EN10305-3
Approvals	VdS, FM, FG, CNBOP, SBSC, LPCB, SETSCO
Type of tubing	HF welded
Welding deterioration reduction	100% EDDY CURRENT tested according to SEP 1925
Weld slag removal	Outside weld flat, insight raising max. 0.5 mm, for dimensions >54 mm 0.8 mm
Tolerance	According to EN10305-3
Finishing	Zinc coating of at least 20µm according steel grade ZNT275. The tube welding seam is subsequently galvanized on the outside.
Surface finish	Silver-coloured
Marking	VSH XPress Sprinkler Galvanized, DN/size x wall thickness mm, LPCB, VdS, G4080007, (working pressure VdS) bar, <FM>, (working pressure) FM psi, DNV, GL, batch number or production date, supplier code
Smallest bending radius	3.5 x external diameter of the tube (max. 28 mm)
Supply mode	Tubes, length of 6 m +0/-50 mm, with protective caps
Heat expansion coefficient	0.0108 mm/m with ΔT= 1K
Max. operating pressure	16 bar

*76.1mm - 108mm pending LPCB approval

Material specifications of XPress Sprinkler Stainless tube

	1.4401 (316)	1.4521 (444)	1.4520 (439)
Material	X5CrNiMo 17 12 2 Material no. 1.4401 according to DIN-EN 10088-2	X2CrMoTi 18 2 Material no. 1.4521 according to DIN-EN 10088-2	X2CrTi17 Material no. 1.4520 according to DIN-EN 10088-2
Specifications	EN 10312 – DVGW worksheet GW541 (2004) Table 2	EN 10312 – DVGW worksheet GW541 (2004) Table 2	EN 10296-2
Approvals	DVGW, SVGW, ETA, ÖVGW, BYGGFORSK, STF, PZH, SITAC, CSTBat, WRAS, VdS, FM, CNBOP, SBSC, SETSCO, LPCB, DNV, GL, LR	VGW, SVGW, ETA, FM, ÖVGW, FG LPCB, DNV, GL, LR	FM, FG
Type of tubing	TIG or laser welded	Laser welded	Laser welded
Welding deterioration reduction	100% EDDY CURRENT tested according to SEP 1914/ EN 10246-2	100% EDDY CURRENT tested according to SEP 1914/ EN 10246-2	100% EDDY CURRENT tested according to SEP 1914/ EN 10246-2
Weld slag removal	Outside	Outside	Outside
Tolerances	According to EN 10312 table 2	According to EN 10312 table 2	According to EN 10296-2
Finishing	Annealed under a protective atmosphere W2R	Annealed under a protective atmosphere W2R	Annealed under a protective atmosphere W2R
Surface finish	Matt silver-coloured	Matt silver-coloured	Matt silver-coloured
Marking	VSH XPress DN/size x wall thickness mm Edelstahl/Stainless - Sanitär/Sanitary - GAS 1.4401 W2R EN10217-7 EN10312 DVGW GW541 Reg.nr. DW-7301BM5610 SVGW ÖVGW W1.397 WRAS ETA BYGGFORSK STF PZH SITAC(+symbol) 0168/04 CSTBat(symbol) 14/04-88, VdS G4080037 (working pressure VdS) bar, <FM> (working pressure FM) psi, LPCB Production date/ pressure Production code /Supplier code	VSH XPress DN/size x wall thickness mm Edelstahl/Stainless steel, 1.4521, Sanitär/Sanitary - W2R EN10296-2 EN10312 DVGW GW541 reg. nr. DW-7301BP5610 SVGW ÖVGW ETA <FM> (working pressure FM) psi, LPCB Production date/Production code/Supplier code	VSH XPress DN/size x wall thickness mm Edelstahl/ Stainless steel, 1.4520 Heizung/Druckluft - Chauffage/Air Comprimé - Heating/Compressed Air <FM> (working pressure) psi, LPCB Production date/Production code /Supplier code
Smallest bending radius	3.5 x external diameter of the tube (max. 28 mm)	3.5 x external diameter of the tube (max. 28 mm)	3.5 x external diameter of the tube (max. 28 mm)
Supply mode	Tubes, length of 6 m +/-50 mm, with protective caps	Tubes, length of 6 m +/-50 mm, with protective caps	Tubes, length of 6 m +/-50 mm, with protective caps
Heat expansion coefficient	0.0160 mm/m with $\Delta T= 1K$	0.0160 mm/m with $\Delta T= 1K$	0.0160 mm/m with $\Delta T= 1K$
Max. operating pressure	16 bar	16 bar	16 bar

*76.1mm - 108mm pending LPCB approval

XPress flexible hoses

Technical data XPress flexible hoses	
Sprinkler hose	Type RS 339L92, DN20/DN25, flexible design with braiding, completely made of stainless steel, welded fittings
Sprinkler connection (straight)	Stainless steel bend pipe thread as per DIN EN 10226 (ISO 7/1), Rp" (SW 27). Scaling for simple vertical alignment. Application when space is limited. Installation height (x) only 170 mm above lower edge of suspended ceiling
Sprinkler connection (90° design)	Stainless steel bend pipe thread as per DIN EN 10226 (ISO 7/1), Rp" (SW 27). Scaling for simple vertical alignment. Application when space is limited. Installation height (x) only 170 mm above lower edge of suspended ceiling
Connection to water supply	Stainless steel straight pipe end with diameter of 22 or 28 mm to be connected with XPress Sprinkler fittings
Nominal length	800, 1000, 1500 and 2000 mm
Maximum operating pressure	16 bar, 100% leak tightness tested

XPress system tube

XPress sprinkler tubes are available in the dimensions DN20 to DN100 (22-108mm). Entry of dirt during transportation or storage is prevented by caps at both ends of the tube and utilizing the correct packaging for distribution.

Fire behaviour

XPress sprinkler tubes are classified as non-combustible red tubes of building material class A, DIN 4102, part 1.

XPress sprinkler system – Galvanised steel tube

The XPress sprinkler Galvanized tubes (SC645) for wet sprinkler systems are thin-walled precision steel tubes. The tubes are made from cold rolled steel that is galvanized using the Sendzimir process. During this process zinc is brought onto the metal strip, running through a zinc bath, covering both sides simultaneously. The tube is protected both on the inside and outside with a zinc layer. The thickness of this layer is minimal 20 µm.

After welding the welding seam zinc is reapplied sealing the seam. With the Sendzimir process a good adhesion of the zinc layer and corrosion resistance are achieved.

XPress Galvanised Sprinkler system tube can only be used in a sprinkler installation and should not be used in a general plumbing application.

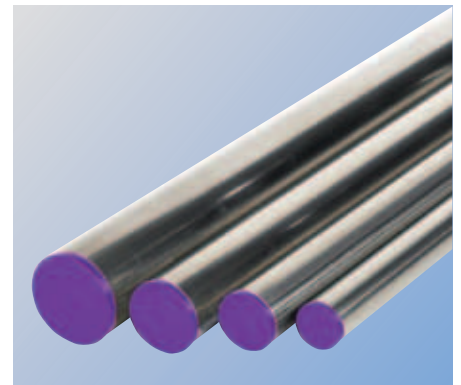

XPress 316 system – Stainless steel tube

The XPress sprinkler Stainless tubes (SS600, SS620, SS630, SS640) are suitable for wet and dry sprinkler systems and are thin-walled precision steel tubes. The outer- and inner surfaces of the tubes are blank, free of discolouration and are supplied free of manufacturing residue that could otherwise cause corrosion. The strict size tolerances and welding seam quality are checked on both the outside and inside.

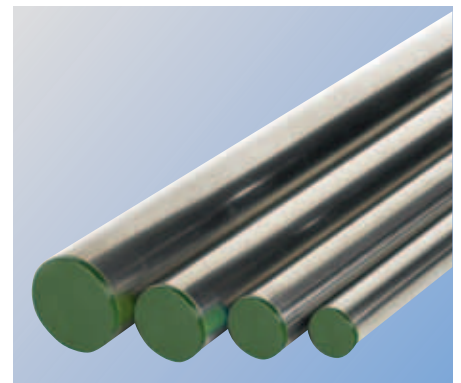

Technical data

System design considerations and tube expansion

When looking at more traditional connection methods, the products used in sprinkler installations are often approved as a product only. The XPress Sprinkler range is a complete system, where the combination of tube, fitting and tools are combined into a certified sprinkler system. XPress Galvanised Sprinkler system tube can only be used in a sprinkler installations and should not be used in a general plumbing application. The components of which our XPress Sprinkler system consist are:

- XPress Sprinkler fittings either in carbon or stainless steel in the dimensions 22-108mm
- XPress Sprinkler tubes, which can be Sendzimir tube in combination with our carbon steel fittings, but also 3 different grades of stainless steel for our stainless steel fittings, depending on relevant approvals
- XPress Sprinkler press tools, either battery or mains operated
- Accessories such as our flexible hoses, especially adapted for an optimal combination with our XPress Sprinkler fittings and installation tools

XPress sprinkler fittings

The XPress sprinkler fittings are available either in carbon or in stainless steel. The carbon steel fittings are manufactured from unalloyed steel (material 1.0034/St 34-2) and are protected against corrosion by means of a zinc layer (8-15 µm) which is applied by electroplating.

The stainless steel fittings are manufactured from stainless steel (material 1.4404 /AISI 316L). XPress Sprinkler fittings are equipped with an EPDM O-ring as standard in the dimensions DN20 to DN100 (22-108 mm).

All XPress fittings are equipped with LBP functionality as standard to reduce the risk of installation errors.

The joint between the tube and the fitting is created by pressure using a press tool. The fitting sleeve is deformed and adapts to the surface of the tube, which is then pressed in turn against the sealing rings on the surface of the fitting. This process ensures the sealing effect and prevents the tube from slipping out.

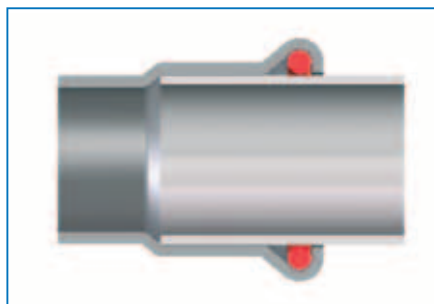

Before pressing

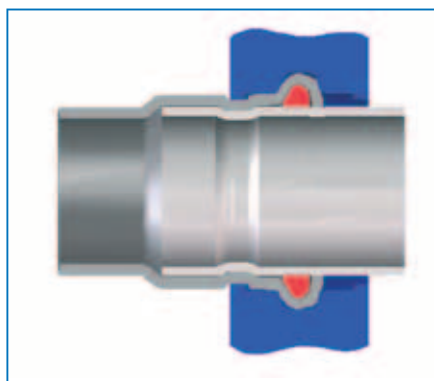

After pressing



XPress 'Leak Before Press'

Thanks to the special grooves in the 'O' ring the Leak Before Pressed 'O' ring (LBP) ensures optimum control of the system during pressure testing (such as for example described in the CEA 4001, no. 17.1.1). Unpressed joints will leak water resulting in pressure loss and are afterwards easy to detect. During the pressing procedure the 'O' ring deforms, closing the special grooves, and the connection between the tube and fittings is sealed, ensuring a water tight joint.



Making a press connection is very easy, especially due to the light weight of fittings and tube and the machine controlled process which is taking place during the connection of tube and fitting. To always ensure an optimal connection between tube and fitting it is mandatory to follow up the installation instructions which are illustrated below, and which are also supplied on each bag of fittings.

Transport and storage

During transport and storage of XPress Sprinkler tubes and press fittings it is important to avoid damage and soiling. The best storage temperature for fittings and tubes is between 10°C and 25°C and they should be stored in a dry area (maximum humidity 65%). The storage of tubes should be horizontal, separated by wooden blocks. Don't stack the bundles too high to prevent tubes from getting oval (the maximum height should not exceed 6 bundles, when stacking stack in 2x2/3x3, etc.). Please make sure not to mix tube materials (carbon and stainless steel) in storage.

Cutting the tube to size



After the measurements have been taken, the XPress Sprinkler tube can be cut to size with a tube cutter, a fine-toothed handsaw or a mechanical saw with motor suitable for the tube material.

The tube should always be cut completely. Never partially cut the tube and then break it (this could cause corrosion).

Do not use oil cooled saws, abrasive wheels or flame cutting

Deburring the tube

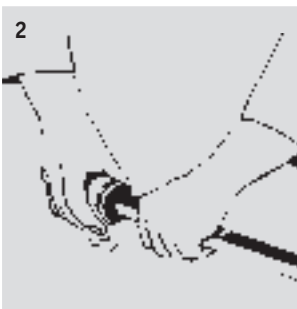

The tube ends should be carefully deburred on the inside and outside after cutting to length to prevent damages to the sealing ring when the tube is inserted into the press fitting. Deburring can be carried out both on the inside and outside either using a manual or an electric deburring tool.

Burrs sticking to the tube must be removed.

Insertion depth marking

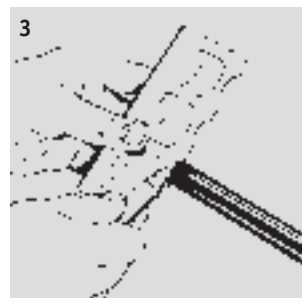

Mark the insertion depth on the tube in order to guarantee a safe and proper connection with a suitable marking tool as supplied by Pegler Yorkshire. Reliable pressing with the corresponding tensile strengths can only be achieved by a proper installation. The pressing operation behind the crimp is of crucial importance

for the tensile strength. The marking on the tube must remain visible (but close to the fitting) after the connection is pressed to identify any movement before or after pressing.

Check the fitting and tube



Before assembly, the fitting must be checked to ensure the correct position and presence of the 'O' rings. The tube, fitting and 'O' ring should be examined for foreign material (e.g. dirt, burrs), which should be removed if present.

Assembly of fitting and tube



Insert the tube into the press fitting up to the marked insertion depth while being rotated slightly and pushed in an axial direction at the same time. The marking for the insertion depth must still be visible. In case of fittings without a stop the fittings should be inserted at least as far as the marked insertion depth.

Rough and careless insertion of the tube into the press fitting may result in damage to the 'O' ring and is therefore not permitted. When assembly is more difficult due to permitted tolerances in sizes, a lubricant as water or soap may be used, but never use oil or grease.

Under no circumstances oils or grease may be used as lubricants

Sprinkler systems Installation instructions

For practical reasons and in order to optimize the installation time, it is standard procedure to establish a certain number of connections first before pressing the different connections one after the other.

Before the final pressing operation is carried out for the different tube connections, always check the minimum clearances which are listed in the table below.

This makes it important to mark the insertion depth as described under insertion depth marking

Pressing

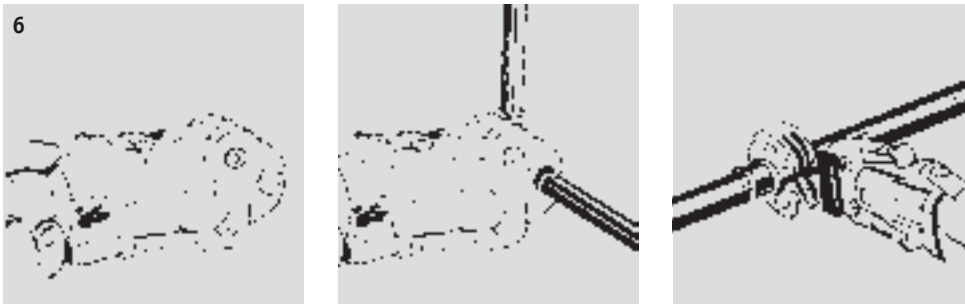

Before starting to press, the press jaws and slings must be checked for dirt, which must be removed if present. Furthermore, it must be ensured that the press machine is in good condition and that the instructions for operating the device, maintenance and the manufacturers' instructions have been followed. Also make sure that you use the correct press jaws and slings for the XPress Sprinkler application. In order to create a proper pressed

connection, the groove of the press tool must enclose the press fitting 'O' ring bead. Once the pressing has started, always complete the press cycle and under no circumstances interrupt the process.

It is not allowed to press a fitting twice or more

Minimum distance between fittings

The XPress fittings are all equipped with the M-profile. To ensure a proper mounting of the press jaws and slings there should always be a minimum clearance available between the fittings. Before the final pressing operation is carried out for the different tube connections, the minimum clearances must be checked against the table below.

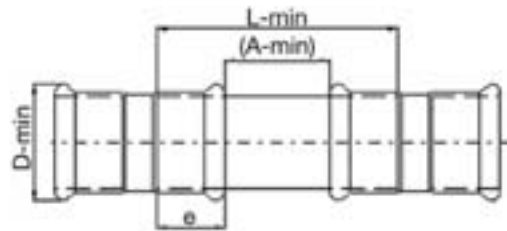

Minimum distance between pressings

DN	Insertion depth		Minimum distance between 2 pressings		Minimum tube length required		
	Outside \varnothing (mm)	e (mm)	A-min (mm)	L-min	2 x e + A-min (mm)	L-min	
		C-steel	St. steel	C-steel	St. steel	C-steel	St. steel
20	22	21	21	10	10	52	52
25	28	23	23	10	10	56	56
32	35	26	26	10	10	62	62
40	42	30	30	20	20	80	80
50	54	35	35	20	20	90	90
65	76.1	55	55	40	40	165	165
80	88.9	63	63	50	50	186	186
100	108	77	77	50	50	234	234

Available space needed for press tool

Using a press tool including the press jaws and slings can be limited due to the available space for the press tool. To make sure that there is enough space available for the press tool, please make sure to follow the minimum distances in the table below. The table below lists the important minimum distances and the space requirement for an installation in order to guarantee correct processing.

The sizes refer to the general installation geometries and are shown schematically in illustrations A, B and C.

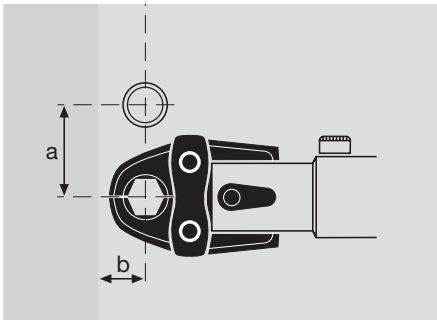

Figure A

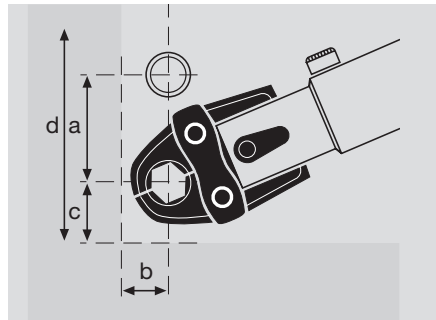

Figure B

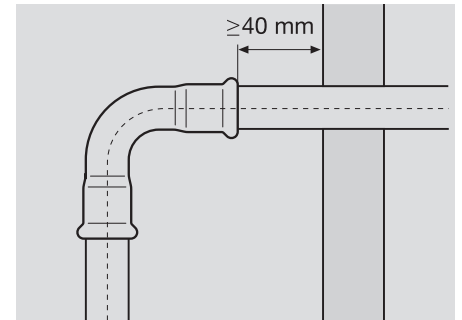

Figure C

Space needed for installation (*press slings)

DN	External \varnothing (mm)	Figure A		Figure B			Figure C	
		a	b	a	b	c	d	Tube depth (mm)
20	22	65	25	80	31	35	150	40
25	28	75	25	80	31	35	150	60
32	35*	115	75	115	75	75	265	70
40	42*	120	75	115	75	75	265	70
50	54*	250	85	120	85	85	290	70
65	76.1*	250	170	200	170	190	390	80
80	88.9*	250	170	250	170	210	460	90
100	108*	250	170	250	170	210	460	100

Bending

Depending on the system, it may be necessary to bend the tube during installation. For this, commercially available manual, hydraulic or electric bending tools with the corresponding bending segments are used. The suitability of the bending tool is defined by the manufacturer. XPress sprinkler tubes for sprinkler installations are cold pliable in the sizes 22 and 28mm.

The minimum bending radius is as follows:

Carbon and stainless steel tube	$r_{min} = 3.5 \times d$ (max. 28mm)
XPress flexible hoses	22mm = 70mm 28mm = 85mm

Due to the danger of corrosion the tube must not be bent when it is warm

General instructions for use

Flushing the network

After completion of the installation work the entire sprinkler system has to be thoroughly rinsed through with filtered (drinking) water. Flushing of the system is necessary in order to guarantee that it is working correctly and to prevent contamination within the system. After the system has been rinsed through it has to be drained off. The sprinklers then have to be attached after the removal of all the materials required for flushing the network.

Filling and bleeding the tube network

After flushing of the tube network has been carried out, the network should be filled with filtered drinking water and completely bled.

Pressure testing

The tubes belonging to the sprinkler system must be subjected to a pressure test according to valid guidelines, for example CEA 4001, no. 17.1.1. (VdS). In general testing should last at least two hours at a the test pressure (measured at the alarm valves) corresponding to 1,5 times the maximum operating pressure - but at least 15 bar - must be maintained. The pressure loss, for example due to temperature changes, should be monitored for 24 h. Dry sprinkler

systems shall also be tested pneumatically to a pressure of not less than 2,5 bars for not less than 24 hours. Every leakage which occurs and results in a pressure drop of more than 0.15 bar for the 24 h, shall be corrected. Any faults disclosed, such as permanent deformations, ruptures or leakages shall be corrected, and the pressure test must be repeated.

Flow loss

Every fluid that flows through a tubing system experiences continuous and local flow resistances that are apparent from the pressure drop in the system. There is a difference between the continuous and the local pressure drop. The continuous pressure drop is mainly caused by the flow resistance in straight tube sections, which in turn essentially results from the friction between the fluid and the tube wall. Local pressure drops, on the contrary, are those flow resistances that are caused by turbulence, for instance where there is a change of internal tube diameter, a tube branch, in an elbow, etc.

Continuous pressure drop

To calculate the total pressure drop resulting from the flow of fluids in a straight section of the tubing system, first determine the pressure drop over a unit of length and then multiply the total length with this value. This value can be determined analytically using the Hazen-Williams formula.

$$p = \frac{6.05 \times 10^5}{C^{1.85} \times d_i^{4.87}} \times Q^{1.85}$$

p = pressure loss in the tube [bar/m]
 Q = flow through the tube [l/min]
 d_i = mean internal diameter of the tube [mm]
 C = constant for type and condition of the tube $C=140$ for XPress Sprinkler tube

The pressure loss due to velocity may be ignored.

Local pressure drops

Local pressure drop is, as mentioned in the introduction of this section, the resistance to flow that results from changes in the flow direction and cross-sectional area, flow splitting over several channels, etc. There are in general two possibilities to calculate these flow resistances: the direct analytical method and the method using equivalent lengths.

Equivalent length method

This is a calculation method that solves the calculation problem as a function of a particular local resistance and gives the equivalent length of a straight piece of tube with the same diameter that would have the same pressure drop. In order to use this method of calculation all length-equivalent values for each fitting type in

the table below are to be added to the actual length of the supply network. The total calculation of the equivalent length is multiplied by continuous pressure drop [bar/m]. This will show the overall resistance in the circuit. This method is not as accurate as the direct analytical method but has the advantage that the calculation can be carried out faster.



Table of equivalent meters

DN20 - 100 (Ø 22 - 108 mm)

DN	mm	Method of equivalent length (m)									
20	22	1.4	0.6	0.5	0.5	0.4	0.8	1.2	1.4	2.8	
25	28	1.9	0.9	0.6	0.6	0.5	1.1	1.5	1.9	3.8	
32	35	2.5	1.2	0.8	0.8	0.7	1.5	2.1	2.5	5.0	
40	42	3.1	1.4	1.0	1.0	0.9	1.8	2.6	3.1	6.2	
50	54	4.0	1.8	1.3	1.3	1.1	2.3	3.3	4.0	8.0	
65	76.1	6.1	2.8	1.9	2.4	0.5	4.7	6.1	7.1	14.2	
80	88.9	7.8	3.6	2.4	3.0	0.6	6.0	7.8	9.0	18.0	
100	108	10.6	4.9	3.3	4.1	0.8	8.2	10.6	12.3	24.6	

Direct analytical method

The local pressure drop can be calculated with the following mathematical equation:

$$\Delta p_L = \sum \zeta \times v^2 \times \gamma / 2 \times 10^{-5} \text{ [bar]}$$

v = flow velocity of the fluid [m/s]

γ = specific density of the fluid [kg/m³]

ζ = local flow resistance coefficient

The table below gives the [ζ] values for every type of fitting. We can assume that [ζ] is velocity independent for those velocities that occur in domestic installations or in other normal applications; this is supported by the fact that the change of [ζ] as a function of the Reynolds number in these velocity ranges is only minimal. Once the [ζ] value is known, one can read off directly the corresponding local pressure drop.



Table of localized flow loss values

DN20 - 50 (Ø 22 - 54mm)

ζ Direct analytical method										
1.5	0.7	0.5	0.5	0.4	0.9	1.3	1.5	3.0		

DN65 - 100 (Ø 76.1 - 108mm)

ζ Direct analytical method										
1.3	0.6	0.4	0.5	0.1	1.0	1.3	1.5	3.0		

XPress sprinkler tools

An important part of the XPress Sprinkler range are the press tools which are used to make a press joint. The tools which we prescribe for the XPress Sprinkler range consist of a press machine and the accompanying press jaws or slings.

Depending on the outside diameter of the tube, you should choose the corresponding press jaws or slings to ensure a completely tight joint.

Only tools made by Novopress for the dimensions DN20 to DN100 (22-108mm) or Klauke for stainless steel in the dimensions DN65 to DN100 (76.1-108mm) (suitable for M-Profile) are permitted to be used

in combination with the XPress Sprinkler system. Other brands of machines and press jaws or slings are currently not permitted due to the certification of our sprinkler range.

Sprinkler approved machines Novopress and Klauke

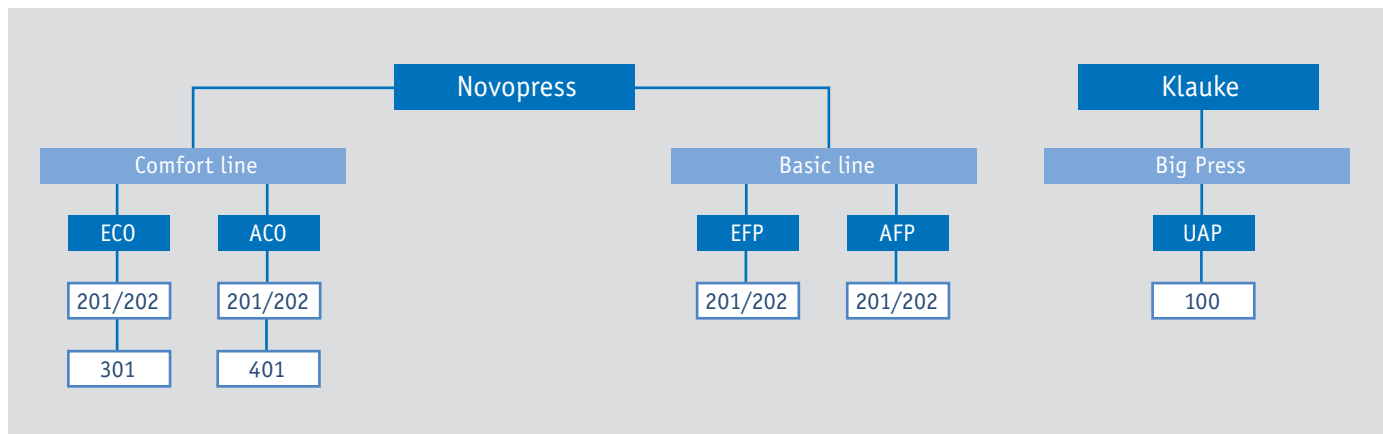

Range of approved Novopress press machines

Novopress ACO 202 DN20-50 (22-54mm)



Power supply	18V/ 3.0Ah
Power	400W
Piston force	32kN
Piston stroke	40mm
Dimensions L x W x H	410 x 80 x 125mm
Weight	3.3kg

Pegler Yorkshire has passed the different certification tests for XPress Sprinkler with a wide range of machines from Novopress. Depending on the dimensions to be installed and the worksite, different machines can be used.

The Novopress ACO 202 is the preferred work site machine for the dimensions DN20 to DN50 (22-54mm).

- Suitable for dimensions from DN20 to DN50 (22-54mm)
- ACO is battery operated with Li-Ion technology

- The low weight and ergonomic shape render even narrow press areas readily accessible
- Convenience features, such as the electronically controlled press procedure with automatic return and electronic retaining bolt securing device, guarantee perfect pressing
- The diagnostic function enables optimum fault analysis for targeted servicing
- Short press cycles, irrespective of the nominal widths, guarantee fast and economical working procedures

Novopress ECO 301 DN20-50 (22-54mm)



Power supply	220 - 240V/50Hz
Power	560W
Piston force	45kN
Piston stroke	45mm
Dimensions L x W x H	420 x 85 x 110mm
Weight	5.0kg

The Novopress ECO 301 is the preferred workshop machine for the dimension DN20 to DN50 (22-54mm).

- Compact dimensions, suitable for dimensions from DN20 to DN50 (22-54mm)
- ECO 301 is mains operated
- Control and monitoring of the entire press cycle is carried out by a microprocessor which ensures optimum press performance at all times over the entire period of use

- The simple operation and ergonomic design render even narrow press areas readily accessible
- Fast and economical. Short press cycles of approx. 12 seconds irrespective of the nominal widths
- The electronic retaining bolt securing device and automatic return after completion of the press cycle are tried and tested standards

Novopress ACO401 DN65-100 (76.1-108mm)



Power supply	18V/3.0Ah
Power	400W
Piston force	100kN
Piston stroke	60mm
Dimensions L x W x H	660 x 100 x 250mm
Weight	13.0kg

When pressing sprinkler installations in the dimension DN65 to DN100 (76.1-108 mm) the machine of choice is the Novopress ACO401.

The ACO401 press machine is a perfect solution for fire sprinkler systems, potable water, ship building and industrial purposes. The dimensions DN65 to DN100 (76.1-108mm) can be pressed in a safe and reliable way by using the special HP401 slings.

- Control and monitoring of the entire press cycle is carried out by a microprocessor which ensures optimum press performance at all times over the entire period of use

- The simple hand operation of the machine allows the installer work at locations that are difficult to access (e.g. ceilings)
- Automatic processing including the return after completion of the press cycle is a proven standard
- Press cycles of ca. 25 seconds, independent of nominal diameter enable fast and economical performance
- The cylinder including sling adaptor can be turned 180° and enables installation at difficult access locations

Other approved Novopress machines for the dimensions DN20 to DN50 (22-54mm):

- Novopress ECO 201 and 202
- Novopress ACO 201
- Novopress EFP 2, 201 and 202
- Novopress AFP 201 and 202

Approved Novopress jaws and slings

Depending on the outside diameter of the tube the pressing should be executed with a press jaw or a press sling. In the dimensions 22 and 28mm a regular press jaw from Novopress can be used. When going to bigger dimensions the pressing should be done by

means of a press sling (starting from 35mm). Depending on the type of machine different slings can be used, which are specific HP versions. These special XPress Power Slings are especially designed for the XPress Sprinkler system.

Novopress jaws and slings



	DN/dimension	Nominal width (mm)
Press jaws	20	22
	25	28
Press slings	32	35
	40	42
	50	54
	65	76.1
	80	88.9
	100	108

Overview of Novopress press jaws and press slings

Special care should be taken in the combination of press machine and press sling. Always make sure to use the appropriate adapter.

In the table below you can find the different combinations approved of machine and press jaw and sling.

Pressing tools ECO 201/202, ACO 201/202, EFP 2/201/202 & AFP 201/202

	DN/dimension	Nominal width (mm)	Adapter
ECOTEC jaw	20	22	-
ECOTEC jaw	25	28	-
Press sling 35	32	35	ZB201/ZB203
Snap on HP 35	32	35	ZB 203
Snap on HP 42	40	42	ZB 203
Snap on HP 54	50	54	ZB 203

Pressing with ECO 201/202, ACO 201/202, EFP 2/201/202 and AFP 201/202 press tools

Pressing tool ECO 301

	DN/dimension	Nominal width (mm)	Adapter
ECO 301 jaw	20	22	-
ECO 301 jaw	25	28	-
Press sling 35	32	35	ZB 302
XPress power sling	40	42	ZB 302
XPress power sling	50	54	ZB 302
Snap on HP 35	32	35	ZB 303
Snap on HP 42	40	42	ZB 303
Snap on HP 54	50	54	ZB 303

Pressing with ECO 301

Pressing tool ACO 401

	DN/dimension	Nominal width (mm)	Adapter
Press sling HP 401 76.1	65	76.1	-
Press sling HP 401 88.9	80	88.9	-
Press sling HP 401 108	100	108	-

Pressing with ACO 401

Range of approved Klauke press machines (only for stainless steel)

For stainless steel installation in the dimensions DN65 to DN100 (76.1-108mm) it is also allowed to use the Klauke UAP100 in combination with Klauke slings

Press slings UAP 100 DN65-100 (76.1-108mm)



Press sling	DN/dimension	Nominal width (mm)
KSP 3	65	76.1
KSP 3	80	88.9
KSP 3	100	108

Overview of Klauke press slings

If the press tools are correctly used, reliable pressing with the XPress Sprinkler system is guaranteed. Regular maintenance and lubrication of the press jaws, slings, adapters and tools is required. Please see the Novopress and Klauke instructions for use and maintenance.

For information on tooling for the XPress sprinkler system, please contact the Pegler Yorkshire helpdesk on 0800 156 0050

XPress

Sprinkler systems
Notes





Pegler Yorkshire

Our brands:



UK sales

Free Phone: 0800 156 0010
Free Fax: 0808 156 1011
Email: uk.sales@pegleryorkshire.co.uk

Export

Tel: +44 (0) 1302 855 656
Fax: +44 (0) 1302 730 513
Email: export@pegleryorkshire.co.uk

Technical Help

Free Phone: 0800 156 0050
Free Fax: 0808 156 1012
Email: tech.help@pegleryorkshire.co.uk

Brochure Hotline

Free Phone: 0800 156 0020
Free Fax: 0808 156 1011
Email: info@pegleryorkshire.co.uk

www.pegleryorkshire.co.uk

Pegler Yorkshire Group Limited

St. Catherine's Avenue, Doncaster,
South Yorkshire, DN4 8DF, England.
Tel: 0844 243 4400 Fax: 0844 243 9870

Registered in England Company No. 00401507
Registered Office: Haigh Park Road, Stourton, Leeds,
West Yorkshire, LS10 1RT, England.

All brand names and logo styles are registered trademarks.
Maintaining a policy of continual product development,
Pegler Yorkshire reserves the right to change specifications, design
and materials of products listed in this publication without prior notice.

LIT.REF: 880187.11.11

